

“An examination of the e-commerce technology drivers in the real estate industry”

Ghaith M. Al Abdallah  <http://orcid.org/0000-0003-3676-7185>

 <http://www.researcherid.com/rid/C-1878-2013>

Azzam A. Abou-Moghli  <https://orcid.org/0000-0002-1943-1965>

Ahmed H. Al-Thani

AUTHORS

ARTICLE INFO

Ghaith M. Al Abdallah, Azzam A. Abou-Moghli and Ahmed H. Al-Thani (2018). An examination of the e-commerce technology drivers in the real estate industry. *Problems and Perspectives in Management*, 16(4), 468-481. doi:[10.21511/ppm.16\(4\).2018.39](https://doi.org/10.21511/ppm.16(4).2018.39)

DOI

[http://dx.doi.org/10.21511/ppm.16\(4\).2018.39](http://dx.doi.org/10.21511/ppm.16(4).2018.39)

RELEASED ON

Wednesday, 26 December 2018

RECEIVED ON

Tuesday, 07 August 2018

ACCEPTED ON

Friday, 21 December 2018

LICENSE



This work is licensed under a [Creative Commons Attribution 4.0 International License](https://creativecommons.org/licenses/by/4.0/)

JOURNAL

"Problems and Perspectives in Management"

ISSN PRINT

1727-7051

ISSN ONLINE

1810-5467

PUBLISHER

LLC "Consulting Publishing Company "Business Perspectives"

FOUNDER

LLC "Consulting Publishing Company "Business Perspectives"



NUMBER OF REFERENCES

36



NUMBER OF FIGURES

4



NUMBER OF TABLES

2

© The author(s) 2021. This publication is an open access article.



BUSINESS PERSPECTIVES



LLC "CPC "Business Perspectives"
Hryhorii Skovoroda lane, 10, Sumy,
40022, Ukraine

www.businessperspectives.org

Received on: 7th of August, 2018

Accepted on: 21st of December, 2018

© Ghaith M. Al Abdallah, Azzam A. Abou-Moghli, Ahmed H. Al-Thani, 2018

*Ghaith M. Al-Abdallah, Department of Marketing, Faculty of Business, Applied Science Private University, Jordan.

*Azzam A. Abou-Moghli, Department of Business Administration, Faculty of Business, Applied Science Private University, Jordan.

Ahmed H. Al-Thani, Department of Management and Marketing, College of Business and Economics University of Qatar, Qatar.



This is an Open Access article, distributed under the terms of the [Creative Commons Attribution 4.0 International license](https://creativecommons.org/licenses/by/4.0/), which permits unrestricted re-use, distribution, and reproduction in any medium, provided the original work is properly cited.

Ghaith M. Al Abdallah (Jordan), Azzam A. Abou-Moghli (Jordan),
Ahmed H. Al-Thani (Qatar)

AN EXAMINATION OF THE E-COMMERCE TECHNOLOGY DRIVERS IN THE REAL ESTATE INDUSTRY

Abstract

This study examined the factors that drive e-commerce technology adoption in the real estate industry in Qatar using the Technology Acceptance Model 3 (TAM3) and sought to analyze the relationship between perceived usefulness, perceived ease of use, anchor factors, adjustment factors and cognitive instrumental variables and their effect on e-commerce adoption in real estate industry in Qatar. The study adopted a descriptive methodology and quantitative research design utilizing survey strategy. 350 filtered and screened questionnaires that were retrieved from the quota sample from 59 real estate firms operating in Qatar were analyzed using AMOS. The results indicated that all the dependent variables have significant relationship with e-commerce adoption indicating that the original model used was a good fit, accounting for a large percentage of the variance associated with e-commerce adoption. However, the results also showed that only perceived usefulness and anchor variables have positive direct effect on e-commerce adoption; perceived ease of use, adjustment variables and cognitive instrumental factors have notable indirect effect on e-commerce adoption.

Keywords

e-commerce, perceived ease of use, perceived usefulness, anchor variables, cognitive instrumental factors, adjustment variables, real estate, Qatar

JEL Classification L81, R10

INTRODUCTION

The real estate sector is booming in Qatar. The rise in oil riches has led to increased investments in its real estate industry, with a growing demand for high quality housing (Colliers International, 2013). Despite the increase in investments, acute shortage of residents in Qatar is still a problem. The influx of experts into Qatar, mainly Doha, has led to the widespread development of real estate sector. According to Zahra (2015), the rising level of expatriates migrating into Qatar means that the real estate industry is likely to experience even higher levels of growth in the near future. The fact that Qatar is hosting the FIFA World Cup in 2022 only adds more pressure on the real estate industry in the country. E-commerce is seen as a way of reaching and attracting new customers who use the internet, which can help the real estate firms enhance their performance and achieve their goals more efficiently (Al-Abdallah, 2015). By not taking this step, real estate firms are not benefiting from the cost reductions associated with applying new technologies. Therefore, it is important to understand the factors that contribute to the successful adoption of e-commerce technologies in real estate firms. Accordingly, the study problem can be expressed in the following question: What are the variables that affect the adoption of e-commerce in the Qatari real estate industry? There

are several theories related to new technologies adoption with several variables for each, this study found that Technology Acceptance Model 3 (TAM3) is more suitable to the nature of this research, since TAM3 is centred around e-commerce in particular (Al-Gahtani, 2014). Accordingly, and to achieve the aim of this study, five main objectives were formulated:

1. To examine the possible effect of perceived ease of use on e-commerce adoption in the Qatari real estate industry.
2. To examine the possible effect of perceived usefulness on e-commerce adoption in the Qatari real estate industry.
3. To examine the possible effect of cognitive instrumental processes variables on e-commerce adoption in the Qatari real estate industry.
4. To examine the possible effect of anchor variables on perceived ease of use in the Qatari real estate industry.
5. To examine the possible effect of adjustment variables on perceived ease of use in the Qatari real estate industry.

1. LITERATURE REVIEW

E-commerce adoption refers to the introduction and implementation of e-commerce within an organization; the organization makes a decision to use e-commerce as part of the business process that improves service availability and delivery to the customer. Many of studies have predominantly focused on two models: the theory of planned behavior and the theory of reasoned action (Gregory, 2011). Both models provide an excellent analysis of the technology adoption process. They both agree that a person's desire to develop a particular action is a factor that ultimately affects the person's actual intentions (Al-Abdallah, 2013). Technology acceptance model is a sort of midwifed theory that went through three different versions known as TAM1, TAM2 and TAM3. They are indications of how hard people are willing to try, of how much of an effort they are planning to exert, in order to adopt the new behavior (Ajzen, 1991, p. 181). Many scholars have also proposed different variables that lead to the recognition and adoption of any technological invention in a business setting. Alharbi and Drew (2014) stated that the primary factor that leads to adopting a new technology is its perceived ease of use. Scholars define perceived ease of use as the measurement at which employees feel free to use technology without any effort. Where Almousa (2013) stated that the perceived

usefulness of e-commerce to businesses is the second factor leading to adoption. When employees and the management view the technology as useful to the business, adoption and implementation processes are not hindered, the usefulness of a technology determines its acceptance and adoption within an organization. Further, social influence factors that relate to subjective norms from the management and employees' perspective, as well as voluntariness towards the use of e-commerce, also have a role to play in the adoption and implementation of e-commerce technology and any other technology. Cognitive instrumental processes factors relate to how the new technology is relevant to the job, how the technology improves service quality, as well as perceived ease of use (Edwin & Peter, 2014). Acceptance of technology is prone to several factors. Different regions of the world also have different factors that motivate e-commerce adoption. In developing countries, the need to compete on a global scale motivates management to adopt e-commerce, but the rate of technology adoption in such countries continues to face several challenges.

1.1. Technology Acceptance Model 3

The Technology Acceptance Model 3 is used widely by scholars to predict the factors that lead to the adoption of e-commerce and other

technologies within the business environment (Al-Gahtani, 2014). TAM3 is a model that presents the drivers, which influence the adoption of information technology (IT) and its implementation within an organization (Venkatesh & Bala, 2008). Based on this model, the determinants of IT adoption include the perceived ease of use, cognitive instrumental process variables, anchor variables, adjustment variables, and the perceived usefulness of technology, these factors affect the organizational adoption of technology or behavioral intentions. TAM3 is ideal, because the adoption of IT and other technologies in an organization should be studied through analysis of organizational intervention. How interventions by organizations to adopt IT (such as e-commerce) are viewed is structured around two categories: pre-implementation and post-implementation. According to Aggorowati et al. (2012), the pre-implementation stage looks at factors that motivate acceptance of IT within an organization. These include employee resistance to new technologies and an original preview of the system so that employee can build a positive perception of it. In addition, pre-implementation of IT technologies is evaluated through design characteristics, participation of the user, participation of the employees, support from managers, and incentives introduced to assist the IT system implementation. Aggorowati et al. (2012) stated that post-implementation as part of TAM3 assesses organizational and management support activities after IT systems has been deployed, such support activities are introduced to improve acceptance levels to the IT system.

The pre-implementation and post-implementation phases as part of the TAM3 focus on the reaction of managers and employees toward the technology to be adopted. As a result, this study focuses on Qatari real estate industry managers and employees' perceptions before and after the implementation of technology. Intervention measures the adoption of technology for certain reasons. The first reason involves the need to minimize the resistance to a new technology by managers and employees, where the second reason involves a review of the system by employees and managers so that they understand the key features of the system necessary for improving job performance.

1.2. Perceived ease of use and perceived usefulness

In terms of cognitive processes, it is necessary to assess the relevance of employee concentration when they are using a new technology. Cognitive concentration influences how new technologies within firms are adopted. In TAM3, though, the role of cognitive concentration is not considered as an isolated factor; factors such as perceived usefulness, perceived enjoyment, and perceived ease of use play a role in the implementation process (Al-Gahtani, 2014). Cognitive concentration among employees relates to perceived enjoyment of the new technology, when employees have high levels of perceived enjoyment, they can concentrate on new technology usage in delivery of quality services. Additionally, the perceived enjoyment of the service is critical to its successful implementation (Salman et al., 2014). Perceived enjoyment as explained in TAM models relates specifically to the completion of tasks (Bradley, 2009). These perspectives define the perceived enjoyment as a general enjoyment gained from using the system, whether the task is completed or not. It should be noted that perceived enjoyment can be a substitute for perceived usefulness, but the adoption of e-commerce and other technologies is affected when perceived enjoyment is used to refer to its perceived usefulness (Surendran, 2012). In fact, perceived usefulness has a greater effect on e-commerce adoption than perceived enjoyment. According to Alharbi and Drew (2014), when a technology is not viewed as being useful, no amount of enjoyment of the technology can positively influence the process of its adoption. Perceived usefulness is therefore more necessary in the technology acceptance rather than perceived enjoyment. According to Ahmad et al. (2014), the perceived usefulness of e-commerce systems for business owners and managers necessitates its adoption. Organizations that have managed to adopt e-commerce view it as an innovation that assists the firm in achieving a competitive advantage. Accordingly, business owners and managers perceive e-commerce as a vital aspect of their business. Some business owners, however, do perceive online buying and selling as methods to only enhance business revenues (Freathy & Calderwood, 2014). The successful adoption of new technologies in business involves learning and accepting new knowledge.

Businesses should be ready to adapt to the use of new technologies so that they achieve competitive advantages in the market. Individual characteristics of organizations and firms also impact how e-commerce is successfully adopted. Age is a major factor that influences the perceived usefulness of a new technology that can improve service delivery and business processes. Al-Qirim (2007) argued that organizations that have existed in the market for several years have a higher level of adoption, which reflects a high level of perceived usefulness, than organizations new to the market. These older organizations, due to their experience of the market across a greater time period, believe that new technologies are more reliable and accountable. As firms grow and age, their failure to successfully adopt new technologies consequently decreases.

A final perceived factor critical to successful e-commerce adoption is the objective of it perceived ease of use, which depends on the level of education of employees and managers (Aoyama, 2013). Employees and managers educated and trained to use e-commerce have high levels of its perceived ease of use, thereby leading to easier adoption within their organizations. A lack of appreciation of the advantages of implementing e-commerce, and the challenges of evaluating these benefits, contribute to low levels of perceived ease of use among organizations willing to do so (Chang et al., 2009).

1.3. Cognitive instrumental process variables

Cognitive instrumental process relates to the achievement of job relevance, the quality of services offered and the demonstrability of the results (Venkatesh & Davis, 2000). Perceptions about e-commerce and its usefulness increase among employees when they can view e-commerce as suitable and necessary for performing tasks within the organization (Porter & Donthu, 2006). In addition, adoption of e-commerce is possible when employees view the technology as leading to high standards of service delivery. If employees are not able to attribute positive results to e-commerce, its implementation experiences challenges (Chuttur, 2009). Experience of the use of the system cannot influence cognitive instrumental processes, because the impact on employee behavior remains

unchanged (Ernst et al., 2014). Hands-on experience of the use of e-commerce affects social influence processes, but not cognitive instrumental one. When employees gain experience in the use of e-commerce, reliance on subjective norms decreases, unless organizational norms are changed, however, the result of adoption remains the same.

1.4. Anchor variables

According to Al-Gahtani (2014), four anchor variables affect the adoption of new technologies in organizations: computer self-efficacy, anxiety in relation to computer use, playfulness with computers, and facilitating conditions (or the perception of external control). The adoption of technology, as well as its acceptance within businesses, depends on individuals' different beliefs about computers and how they can be used to deliver efficient services. The successful ability of employees to use e-commerce systems demonstrates that self-efficacy is a core anchor variable for implementing new systems. In particular, employees' belief in their ability to use e-commerce successfully was necessary in controlling any anxieties they might have felt. Further, external control has been identified as key to implementation of e-commerce. Computer system playfulness refers to the intrinsic motivations to use a new framework that employees must have. Al-Gahtani (2014) argued that these anchor variables greatly impact perceived ease of use and thus the adoption of a technology.

Salman et al. (2014) also argued that anchor variables contribute to the adoption of e-commerce. Past experience has an influence on the rate of adoption, the experienced employees with e-commerce and other internet technologies are more receptive to the adoption of e-commerce, when a person views positively the use of a new system before they gain any hands-on experience, the process of adoption and implementation is likely to be easier.

1.5. Adjustment variables

Adjustment to new system depends on enabling employees to obtain hands-on experience with that system. Yet, as e-commerce is relatively a new technology for most businesses in developing countries, hands-on experience necessary for

employees' adjustment may not be possible in certain situations (Surendran, 2012). In addition to the role of experience as an adjustment variable, employees' perceptions of the firm's resources made available for implementation and computer self-efficacy still play roles in the adjustment variable. Perceived enjoyment and perceived ease of use also improve adjustment towards the successful use of the system (Alharbi & Drew, 2014).

Chen et al. (2011) included the degree to which an employee believes that they can perform certain tasks (in this case, by using e-commerce) to the adjustment variables, many employees have low computer self-efficacy and the fear of using computers, though, because they have never used e-commerce to conduct and perform certain tasks within the organization. Knowledge on the use of the technology eliminates any anxiety that may impact the delivery of services through e-commerce. Employee perception of the usability and enjoyment of using e-commerce and any other technology has an influence on the adjustment process (Al-Adwan et al., 2013).

1.6. Social influence

An organizational culture that motivates the development of innovations is likely to motivate employees to look for new methods that improve services within an organization (Downing, 2006). Social influences relate to how an organizational culture can influence all employees to support new technologies. The culture within the organization should be supportive towards training and development so that all employees acquire the necessary knowledge to best use new technologies (Freathy & Calderwood, 2014).

Based on Iqbal (2012), organizations that work with large amounts of data, as well as the ones that engage in large volumes of transactions, may adopt new technologies such as e-commerce to improve the quality of their services. In such cases, the perceived usefulness of the new technology becomes a critical component that motivates the management to adopt e-commerce as a new technology. According to Karakaya and Shea (2008) the adoption of e-commerce is necessitated by the perception that it can increase firms' competitive market position. Challenges to this perception

arise when the customer, suppliers, or distributors are not willing to embrace the new technologies (Mazzarol, 2015; Al-Abdallah et al., 2014a).

Costs and return on investment are further factors that impact the adoption of e-commerce. They contribute to the perceived usefulness of e-commerce. Resource limitations in terms of time and capital influence the successful implementation of e-commerce within businesses, as such limitations alongside entrenched use of traditional systems, limit the firm's ability to gain from the new technologies (Tabor, 2014). Most businesses are concerned about survival rather than finding solutions such as e-commerce. Reluctance to adopt e-commerce thereby stems from an inability to invest in long-term projects when short-term returns are not guaranteed (Tseng et al., 2015).

According to Wilson et al. (2008), e-commerce is viewed as a technology that affects human interaction with customers, Junk mail as well as lack of interaction with the customer, affect the successful use of e-commerce by all stakeholders. Social influence factors such as lack of awareness by business owners also limit the perceived usefulness of the new technology. Other factors such as computer literacy also contribute to low levels of e-commerce adoption within firms. Social influences can also include any mistrust and security risks that arise from the use of e-commerce (Wu & Hisa, 2008). E-commerce services adoption by an organization depends in particular on its ability to guarantee consumer privacy and confidentiality. A seemingly lack of time for business owners also forms a social influence that can limit the adoption of e-commerce as a means to improve service delivery (Ahmad et al., 2014).

Bodini and Zanolli (2011) asserted that resistance to change is another social issue that negatively affect the adoption of e-commerce; which may be motivated by the fact that new technologies may not achieve the desired outcome in the short term, employees should be empowered so that they feel no need to resist new technologies likely to improve service delivery within the organization. Freathy and Calderwood (2014) argued that external factors also contribute to e-commerce adoption, such as culture, which include whether the consumers' society is likely to support online

buying, and variations in trust between one society and another is a further complication meaning that some societies are not likely to embrace online buying. Social-economic which include the ability of the customer to access the internet and its affordability also shape the widespread success of e-commerce, political, and legal frameworks that affect successful adoption of e-commerce (Al-Abdallah et al., 2014a).

2. METHODS

This empirical study utilized descriptive methodology, as it is describing the e-commerce adoption by the real estate industry in Qatar without any alteration or manipulation of the examined variables. To achieve this end, quantitative research design was found suitable for the nature of this study. The researchers began by examining existing theory and developing hypotheses, which then can be tested during the analysis to explain different possible relationships between factors related to e-commerce adoption in the real estate industry. Survey strategy utilizing questionnaire was adopted as the study instrument. AMOS version 23 was used to describe and analyze the data of this study.

2.1. Target population

The target population for this study is the employees of real estate firms in Qatar. They were selected because the study seeks to understand factors that influence e-commerce adoption in the Qatari real estate industry, which is done by the employees being the ones dealing with the new technologies in their organizations. According to Qatar Directory (2018), the real estate sector in Qatar is composed of 284 firms that offer services of buying, selling or renting of properties such as open lands and residences. Real estate activities in Qatar also include the marketing of such properties and activities related to property management and developments. Due to the wide scope of covered activities under the name of real estate, it is hard to determine precisely the total number of employees in this sector especially with the lack of official statistics in this field. The majority of the 284 real estate firms in Qatar are small and medium ones, with very few large firms, however, these few large firms employ

more people than the remaining small and medium firms combined. Convenience sampling was first applied and the total number of the selected firms from the market – influenced with some factors such as the time available to conduct the study and the ability to access these firms – accounted to 59. These firms are the strata of the study and consisted of three large firms, which consisted of approximately of 13,000 employees, and the remaining 56 are medium and small firms consisted of approximately of 50 to 90 employees each. All the selected firms are located in Doha, being the main city in Qatar and the capital of all economic activities in the country.

2.2. Sample

The study used a sample size of 250 participants in order to ensure representativeness. A total of 487 questionnaires were originally distributed, 389 were returned, and only 350 were used after the filtration process. To select the respondents, a quota sampling approach was used, which made the sample more representative of the study population and hence improved the reliability of the study results and improved the validity (Novikov, A., & Novikov, D., 2013). The quota was adopted in order to choose participants across three scales of organizations examined in this study. This approach was considered, because it ensures that each of the objects of the study population have actually represented the targeted population accurately and proportionally. This allows the researchers to be able to divide the study population into groups that can be effectively studied independently (Kothari, 2004; Balnaves & Caputi, 2001; Hussain, 2011).

2.3. Questionnaire

The questionnaire was developed based on the TAM3. The questionnaire statements were outsourced from previous studies. It focused on 27 questions that cover the five areas mentioned in the conceptual model of TAM3. The first question is a control one aimed at making sure that the participant has dealt with new technologies in his organization before. The next six questions sought to gather demographic information from the participants regarding their characteristics and their internet usage. It should be noted that none of the

questions focused on gathering private or personal data from the study respondents. The next part of the questionnaire included 20 items from the TAM3 categories. These categories included anchor variables, adjustment variables, and perceived ease of use, perceived usefulness, and cognitive instruments, this part of the questionnaire utilized a five-point Likert scale ranging from strongly agree to strongly disagree. The cover letter and questionnaire were distributed by email to employees of 59 real estate firms in Qatar.

2.4. Validity of the research

Research validity is defined as the degree to which the study instrument is able to measure effectively what it is supposed to measure. Face validity is the focus of this study; this is not a validity in its technical sense. Rather, face validity refers to what a test appears to measure and not what it measures, a questionnaire requires face validity so that it appears to be valid for its participants. Face validity was an important test for internal validity and was ensured in several ways. Firstly, there were the questionnaire constructions in a manner that it would make sense to the study participants. Secondly, the focus was on conducting a study that tested whether the study instrument made sense to the expected participants, establishing whether participants were comfortable responding to the research questions or not. Third, the questionnaire was designed with a focus on the generalizability of the study conclusions. Apart from this, the questionnaire was also sent to a panel of experts who are academic professors and experts in the field of the study to help establish face validity (Rama, 2007). These experts provided comments and notes that were used in correcting the study instrument and facilitating the development of the final questionnaire.

2.5. Reliability of the research

Cronbach's Alpha is a test for reliability easily achieved through the use of statistical analysis. A value for alpha above 0.6 indicates the scale used in designing the questionnaire is acceptable in terms of reliability. This study adopted Cronbach's Alpha as a means of testing if the scale used in this questionnaire is internally consistent. The results of the test are shown below. Table 1 shows the Cronbach's alpha results.

Table 1. Cronbach's Alpha reliability statistics

Cronbach's Alpha	Cronbach's Alpha based on standardized items	N of items
.882	.884	20

The Cronbach's Alpha being 0.882 shows that the questionnaire's level of internal consistency is high across the scale used and hence can be considered reliable for use in this study.

2.6. Data analysis

Path analysis is a statistical approach better than multiple regression analysis for the nature of this study, since regression is not able to identify the causal relationships existing among variables (Hussain, 2011). To understand the correlation between the variables, path analysis was used. Path analysis attempts to provide estimates of the magnitude and importance of hypotheses' random connections among a number of variables, which is better explained through a path diagram (Barrett, 2007).

This connection proceeds in a single direction and hence viewed as being comprised of distinct paths (Martin & Bridgmon, 2013). This element is explained through the path diagram, which is perceived as the central feature of this technique. The path diagram is used to portray the obvious and likely causal connections that exist between variables (Neale & Strang, 2015). The use of the path diagram enabled the researchers to understand which of the variables are more important and what the significant paths are. This could have an impact on any pre-specified hypotheses. Despite this, it should be clear that path analysis is not able to identify and show which path should be preferred nor does it show the different correlations that could enable an understanding of any causal relationships (Plonsky & Gass, 2011). In order to conduct the path analysis, two tests were conducted. The first test was a correlation analysis that examined the correlations among the different variables. The second test was a standardized regression analysis that could identify the regression coefficients. This was essential for establishing the regression output formula and diagram to facilitate further analysis.

Source: Adopted from Venkatesh and Bala (2013).

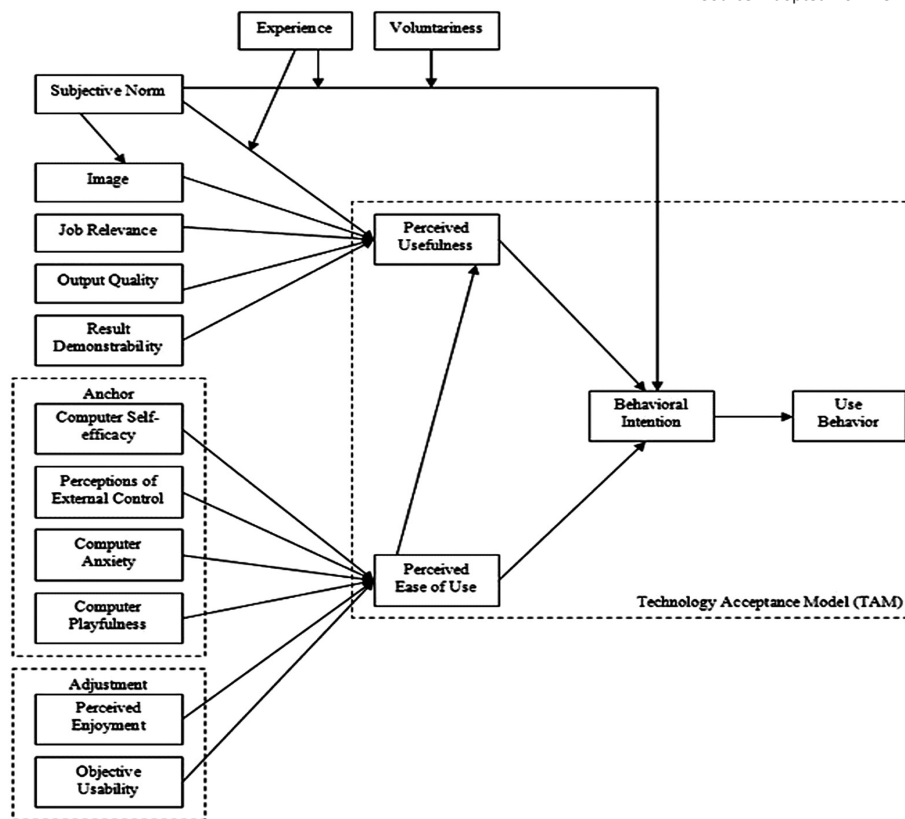

Figure 1. Path analysis diagram

This study's use of TAM3 model already provides an important perspective on the likely paths that the variables could take. The path diagram shows that subjective norms, output quality, result demonstrability, image, and job relevance contribute together to the perceived usefulness, which itself leads to the desire to adopt the behavior (Figure 1). Experience and voluntariness are seen to affect intentions to use and usage behavior. Therefore, path analysis focuses on examining the strengths of the paths mentioned above by conducting multiple regression analysis along them. In this study, these are the perceived usefulness, behavioral intentions, and perceived ease of use.

3. RESULTS

3.1. Demographic characteristics

The three hundred and fifty respondents from the 59 real estate firms that participated in this study

had the following characteristics as displayed in Table 2.

Table 2 indicates that the age with the high number of respondents was between 25 and 34 years old, in total 28.9% of the participants. The lowest, on the other hand, were respondents of 55 years and older at only 10%. 54.6% of the participants had obtained a four years' degree. A minority, 7.7%, had obtained a postgraduate degree. 24.9% of the participants had worked at the real estate firm for more than ten years, 18.6% had worked for between five and ten years, while only 17.1% had worked at the firm for three to five years. 38% of the respondents used the internet on average between 3 and 4 hours for work which were the highest percentage. The lowest were those who used it for more than 5 hours representing 9.5% of the respondents. 28% of the participants use the internet in general on average between 4 and less than 5 hours a day. The lowest group, at only 14.3%, used it for between 1 and 2 hours.

Table 2. Demographic characteristics of respondents

Characteristics	Frequency	Percent	Cumulative percent
Gender			
Male	192	76.8	76.8
Female	58	23.2	100
Age			
18 to less than 25 years	74	21.1	21.1
25 to less than 34 years	101	28.9	50.0
35 to less than 44 years	74	21.1	71.1
45 to less than 55 years	66	18.9	90.0
55 or older	35	10	100
Total	350	100	
Education level			
High school or less	89	25.4	25.4
2 years diploma	43	12.3	37.7
4 years diploma	191	54.6	92.3
Postgraduate	27	7.7	100
Total	350	100	
Working period			
Less than 1 year	63	18	18
1 year and less than 3 years	75	21.4	39.4
3 years and less than 5 years	60	17.1	56.5
5 years and less than 10 years	65	18.6	75.1
10 years and more	87	24.9	100
Total	350	100	
Average hours of using the internet for work			
Less than 1 hour	53	15.1	15.1
1 to less than 2 hours	78	22.3	37.4
3 to less than 4 hours	133	38	75.4
4 to less than 5 hours	53	15.1	90.5
5 hours and more	33	9.5	100
Total	350	100	
Average hours using the internet in general			
Less than 1 hour	60	17.1	17.1
1 to less than 2 hours	50	14.3	31.4
3 to less than 4 hours	80	22.9	54.3
4 to less than 5 hours	98	28	82.3
5 hours and more	62	17.7	100
Total	350	100	

3.2. Findings

Five objectives were designed in order to facilitate the analysis as discussed in the introduction section. Path analysis was conducted using AMOS version 23

to test the objectives and answer the study questions. From the results of the analysis, it was found that $p < 0.001$ for all five variables. This means that the five independent variables are significant predictors of e-commerce technology adoption in the Qatari real estate industry. Additionally, testing the variance of the model coefficients established that all five variables account for 87.4% of the variance in e-commerce technology adoption. All the five independent variables were initially important.

3.3. Path diagram

The following models show the un standardized and standardized estimates of the study model. Through the model, it is easier to determine the relationships among the dependent variables and independent variables.

Based on the statistical analyses, it was found that the perceived ease of use has a largely indirect effect on e-commerce technology adoption ($Beta = -0.070, p < 0.001$). The high level of perceived ease of use of the e-commerce technologies did not result in e-commerce technology adoption in the real estate industry in Qatar. Therefore, increasing the perceived ease of use of e-commerce technology may not result in the adoption of these technologies in the real estate industry in Qatar. Also, it was found that the perceived usefulness of e-commerce technologies had a significant positive direct relationship with e-commerce technology adoption in the real estate industry in Qatar ($Beta = 0.200, p < 0.001$). The high level of perceived usefulness of the e-commerce technologies resulted in higher levels of adoption of the e-commerce technologies in the real estate industry in Qatar. Therefore, increasing the perceived usefulness of the e-commerce technologies in the real estate industry in Qatar will result in high levels of adoption of the e-commerce technologies among users. In addition, it was found that anchor variables had a significant positive direct effect on e-commerce technology adoption in the real estate industry in Qatar ($Beta = 0.222, p < 0.001$). This means that higher levels of anchor variables generated high levels of e-commerce adoption in the real estate industry in Qatar. Therefore, enhancing anchor factors, which include elements such as computer self-efficacy, reduction of computer anxiety, enhancing computer playfulness and reduction of

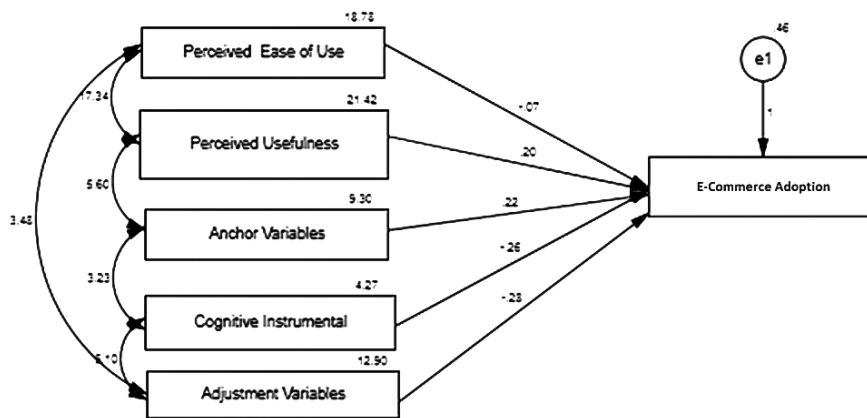

Figure 2. Unstandardized estimates model

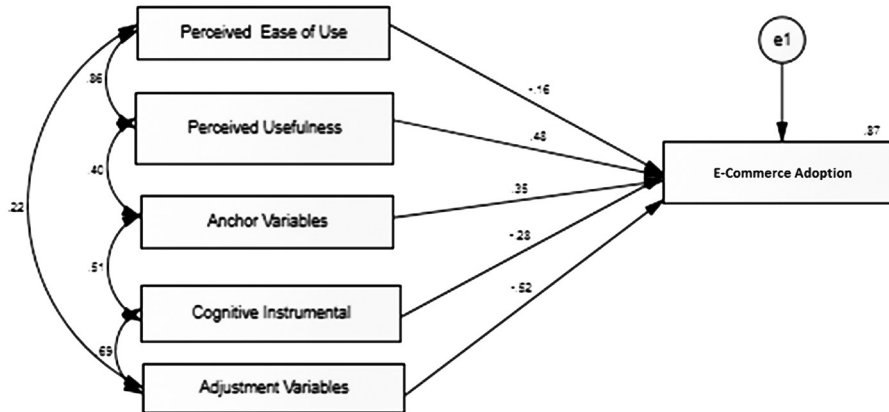

Figure 3. Standardized estimates model

external control, could improve the overall adoption levels of e-commerce technologies in the real estate industry in Qatar. The result indicates that there is a largely indirect relationship between cognitive instrumental process variables and e-commerce technology adoption in the real estate industry in Qatar ($Beta = -0.261, p < 0.001$). This means that higher levels of cognitive instrumental variables would generate lower levels of e-commerce technology adoption in the real estate industry in Qatar. From these results, it can be concluded that an increase in cognitive instrumental variables – which include factors such as job relevance, output quality, and result demonstrability – may not result in increased adoption of e-commerce technologies in the real estate industry in Qatar, rather, it will result in lower levels of adoption. Moreover, it was found that adjustment variables have a predomi-

nantly indirect effect on e-commerce technology adoption in the real estate industry in Qatar ($Beta = -27.6, p < 0.001$). Higher levels of adjustment variables result in lower levels of e-commerce technology adoption in the real estate industry in Qatar. Therefore, an increase adjustment factors such as perceived enjoyment and objective usability of the e-commerce technology systems may not result in increased adoption of the e-commerce technologies, but rather lower levels of adoption.

The path analysis also sought to test the fit of the model. The results of the path analysis indicated the Chi-square value ($X^2 = 1615.512, df = 5$), which is significant ($p < 0.001$), but this was to be expected due to the small sample size ($N = 350$). Other indices that were also considered showed a good fit. Of these, the most positive were Root Mean Square

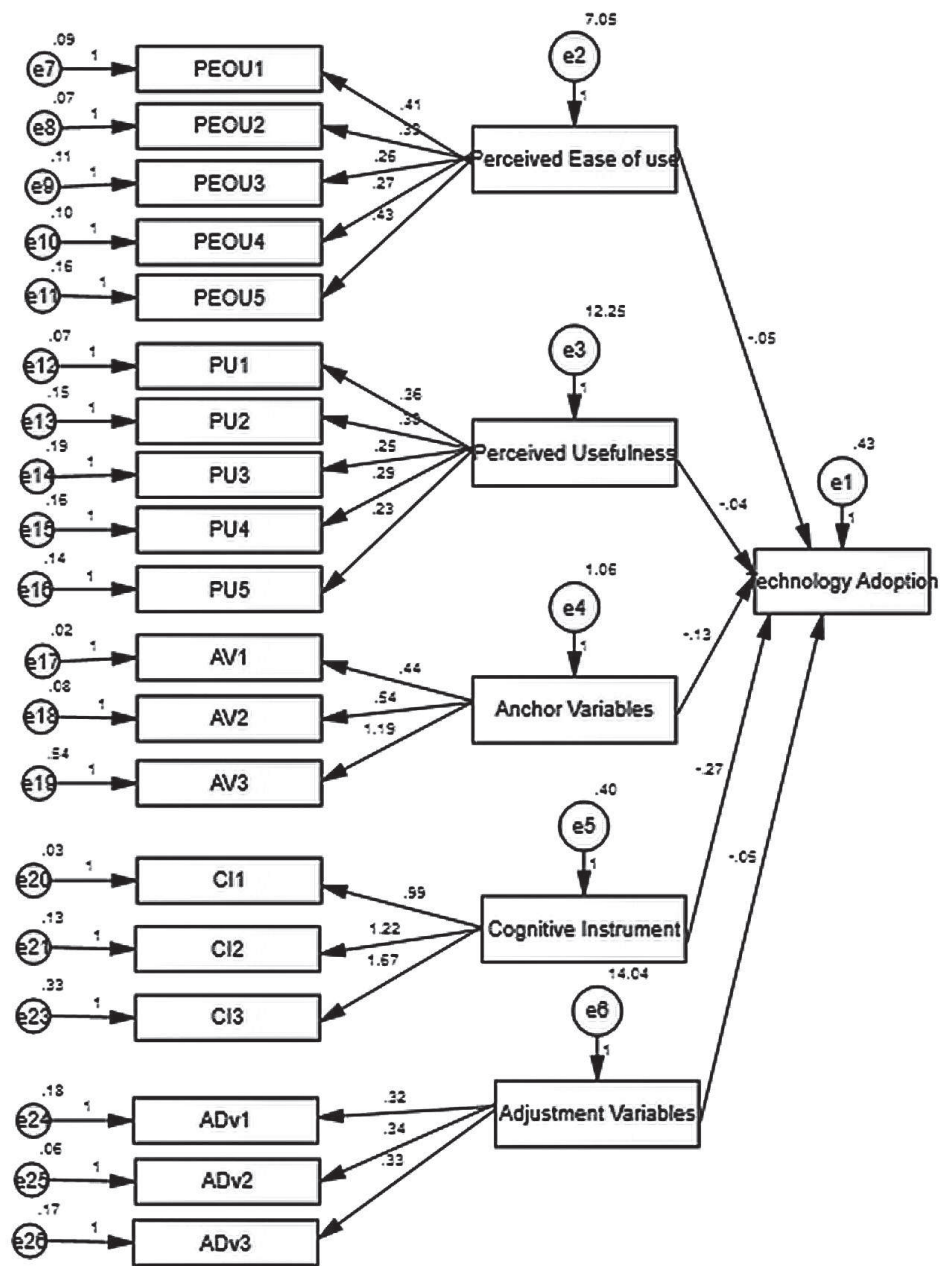

Figure 4. Model results

Residual (0.000) and Goodness of Fit Index (0.52). The model accounted for 87.4% of the variance associated with e-commerce technology adoption ($R^2 = 0.874$). The value established in this model is higher than the variance that was reported in other studies such as Chau and Hu (2001, 2004) who established $R^2 = 0.42$ and $R^2 = 0.43$, respectively.

Last but not least, the study also examined the relationships among the dependent variables in the model and established that all the variables had a

significant positive relationship with the R value being greater than 0.886 ($R > 0.886$, $N = 350$, $p < 0.001$). All the relationships that were tested were found to be strong regarding the strength of the relationships examined. Given that $p < 0.001$ the relationships were perceived as significant at the p level. This means that high levels of one dependent variable were highly correlated with other dependent variables, with the relationship positive in nature. Accordingly, the final model is presented in Figure 4.

CONCLUSION

This study sought to examine the drivers of e-commerce adoption in the real estate industry in Qatar. Using path analysis, the study established a positive direct relationship between perceived usefulness and e-commerce technology adoption and anchor variables and e-commerce technology adoption. On the other hand, an indirect relationship was established between the perceived ease of use, adjustment variables, cognitive instrumental variables and e-commerce technology adoption. Additionally, other variables' strong relationships mean positive correlation among the dependent variables, therefore, from this perspective, it is suggested that there is a need to foster the perceived usefulness and anchor variables in any organization seeking to foster e-commerce technology adoption.

RECOMMENDATIONS

There is no need to focus on the factors that do not directly and positively affect e-commerce adoption, hence, organizations in the real estate sector should optimize their strategies around two variables – perceived usefulness and anchor variables – to ensure ease of adoption. This will not only improve the ability of the firms to complete the process, but also enhance the overall cost effectiveness of the adoption success by reallocating and directing resources only to the variables that proved to be effective.

Organizations seeking to adopt new e-commerce technologies do not have to focus on cognitive instrumental variables, perceived ease of use and adjustment variables as they result in negative effects. Cognitive instrumental variables, perceived ease of use and adjustment variables need to be modified if they are expected to achieve success in the adoption process. Without proper modifications and examination of these factors within organizations, success may not be achieved.

FURTHER RESEARCH

Future research should seek to examine the role of subjective norms on e-commerce technology adoption in the real estate industry in Qatar. In addition, given that technology acceptance model is largely a voluntary model, considering prior experience is something which is important when encouraging the adoption of new technologies. Apart from the subjective norm, prior experience as a factor was not tested in this study, therefore, it will be interesting to test the relationship that exists between this factor and technology adoption in Qatar's real estate industry.

Finally, given that consumers are users of such technologies, they are equally important to technology diffusion in the real estate industry. Thus future research should examine the adoption of e-commerce by consumers to understand the factors contribute to the success or the failure of these technologies in the Qatari real estate industry.

ACKNOWLEDGMENT

*The first two authors grateful to the Applied Science Private University, Amman, Jordan for the financial support granted to this research project (DRGS-2018).

REFERENCES

1. Abbasi, M. R., Sarlak, M. A., Ghorbani, A., & Esfanjani, H. A. (2010). CSFs of e-commerce admission in small and medium size enterprises SMEs. *African Journal of Business Management*, 4(16), 3480-3490.
2. Aggorowati, M., Iriawan, N., Suhartono, S., & Gautama, H. (2012). Restructuring and expanding technology Acceptance Model Structural equation model and Bayesian Approach. *American Journal of Applied Sciences*, 9(4), 496-504. Retrieved from <http://thescipub.com/PDF/ajassp.2012.496.504.pdf>
3. Ajzen, I. (1991). The theory of planned behavior. *Organizational Behavior and Human Decision Processes*, 50(2), 179-211.
4. Al-Abdallah, G. M. (2013). The Effect of Customer-Company Relationship on Internet Adoption in Jordanian Small and Medium Enterprises. *Journal of Economics and Behavioral Studies*, 5(4).
5. Al-Abdallah, G. M. (2015). The impact of Internet marketing research on achieving competitive advantage. *International Journal of Arts & Sciences*, 8(1), 619-627. Retrieved from <http://www.universitypublications.net/ijas/0801/pdf/V4Z374.pdf>
6. Al-Abdallah, G. M., Abdallah, A. B., & Hamdan, B. K. (2014)a. The impact of supplier relationship management on competitive performance of manufacturing firms. *International Journal of Business and Management*, 9(2), 192-202.
7. Al-Abdallah, G. M., Al-Khawaldeh, K. H., & Al-Hadid, A. Y. (2014)b. Internet Usage and Traditional Distribution Channels: The Moderating Effect of the Firm's Size in Jordan. *International Business Research*, 7(3), 81.
8. Al-Gahtani, S. S. (2014). Empirical investigation of e-learning acceptance and assimilation: A structural equation model. *Applied Computing and Informatics*, 12(1), 27-50. <https://doi.org/10.1016/j.aci.2014.09.001>
9. Alharbi, S., & Drew, S. (2014). Using the Technology Acceptance Model in Understanding Academics' Behavioural Intention to Use Learning Management Systems. *International Journal of Advanced Computer Science and Applications*, 5(1), 143-155. <https://doi.org/10.14569/IJAC-SA.2014.050120>
10. Almousa, M. (2013). Barriers to E-Commerce Adoption: Consumers' Perspectives from a Developing Country. *iBusiness*, 5(2), 65-71. <http://doi.org/10.4236/ib.2013.52008>
11. Balnaves, M., & Caputi, P. (2001). *Introduction to quantitative research methods: An investigative approach*. London: Sage.
12. Barrett, P. (2007). Structural Equation Modelling: Adjudging Model Fit. *Personality and Individual Differences*, 42(5), 815-824. <http://doi.org/10.1016/j.paid.2006.09.018>
13. Çelik, H. E., & Yilmaz, E. (2011). Extending the Technology Acceptance Model for Adoption Of E-Shopping By Consumers In Turkey. *Journal of Electronic Commerce Research*, 12(2), 152-164. Retrieved from http://www.jecr.org/sites/default/files/12_2_p03.pdf.
14. Chuttur, M. (2009). Overview of the Technology Acceptance Model: Origins, Developments and Future Directions (Working Papers on Information Systems). *All Sprouts Content*, 290, 1-23. Retrieved from http://aisel.aisnet.org/sprouts_all/290
15. Colliers International (2013). *Doha, Qatar: Real estate market Overview*. Retrieved from <http://content.argaam.com.s3-eu-west-1.amazonaws.com/849b8a32-8d3b-468c-9d3b-397577d19a6e.pdf>
16. Cosgun, V., & Dogerlioglu, O. (2012). Critical Success Factors Affecting E-commerce Activities of Small and Medium Enterprises. *Information Technology Journal*, 11(12), 1664-1676.
17. Davis, F. D. (1989). Perceived usefulness, perceived ease of use, and user acceptance of information technology. *MIS Quarterly*, 13(3), 319-340. <https://doi.org/10.2307/249008>
18. Dholakia, N. (2002). *Global E-commerce and Online Marketing: Watching the Evolution*. London: Greenwood Publishing Group.
19. Dickinger, A., Arami, M., & Meyer, D. (2008). The role of perceived enjoyment and social norm in the adoption of technology with network externalities. *European Journal of Information Systems*, 17(1), 4.
20. Edwin, A. M., & Peter, M. J. (2014). Drivers and Inhibitors to E-Commerce Adoption among SMEs in Nigeria. *Journal of Emerging Trends in Computing and Information Sciences*, 5(3), 192-199. Retrieved from http://cis-journal.org/journalofcomputing/archive/vol5no3/vol5no3_8.pdf
21. Ernst, C. H., Wedel, K., & Rothlauf, F. (2014). Students' Acceptance of E-Learning Technologies: Combining the Technology Acceptance Model with the Didactic Circle. *Twentieth Americas Conference on Information Systems*, 1-7. Retrieved from <http://wi.bwl.uni-mainz.de/Dateien/StudentsAcceptanceofE-LearningTechnologies.pdf>
22. Gregory, S. (2011). The Theories of Reasoned Action and Planned Behavior Applied to Business Decisions: A Selective Annotated Bibliography. *Journal of New Business Ideas & Trends*, 9(1), 43-50. Retrieved from <https://eprints.qut.edu.au/46373/>
23. Hussain, T. P. (2011). *Research Methodology in Physical Education*. New York: Pinnacle technologies.
24. Kim, S. H. (2008). Moderating effects of Job Relevance and Experience on mobile wireless technology acceptance: Adoption of a smartphone by individuals. *Information and Management*, 45(6), 387-393. Retrieved from <http://www.citeulike.org/user/timburrow/article/4849053>
25. Kothari, C. R. (2004). *Research Methodology: Methods and*

- Techniques*. London: New Age International.
26. Lee, S., Ha, S., & Widdows, R. (2011). Consumer responses to high-technology products: Product attributes, cognition, and emotions. *Journal of business research*, 64(11), 1195-1200. <http://doi.org/10.1016/j.jbusres.2011.06.022>
 27. Martin, W. E., & Bridgmon, K. D. (2013). *Quantitative and Statistical Research Methods: From Hypothesis to Results*. London: John Wiley and Sons.
 28. Neale, J., & Strang, J. (2015). Blending qualitative and quantitative research methods to optimize patient reported outcome measures. *Addiction*, 110(8), 1215-1216. <https://doi.org/10.1111/add.12896>
 29. Novikov, A. M., & Novikov, D. (2013). *Research Methodology: from philosophy to Science*. London: CRC Press.
 30. Plonsky, L., & Gass, S. (2011). Quantitative Research Methods, Study Quality, and Outcomes: The Case of Interaction Research. *Language Learning*, 61(2), 325-366. <https://doi.org/10.1111/j.1467-9922.2011.00640.x>
 31. Porter, C. E., & Donthu, N. (2006). Using the technology acceptance model to explain how attitudes determine Internet usage: The role of perceived access barriers and demographics. *Journal of Business Research*, 59(9), 999-1007. <https://doi.org/10.1016/j.jbusres.2006.06.003>
 32. Priem, R. L., Li, S., & Carr, J. C. (2012). Insights and New Directions from Demand-Side Approaches to Technology Innovation, Entrepreneurship, and Strategic Management. *Research Journal of management*, 38(1), 346-374. <https://doi.org/10.1177/0149206311429614>
 33. Rubin, A., & Babbie, E. (2007). *Research Methods for Social Work*. London: Cengage Learning.
 34. Venkatesh, V., & Bala, H. (2008). Technology acceptance model 3 and a research agenda on interventions. *Decision Sciences*, 39(2), 273-315. <https://doi.org/10.1111/j.1540-5915.2008.00192.x>
 35. Venkatesh, V., & Davis, F. D. (2000). A Theoretical Extension of the Technology Acceptance Model: Four Longitudinal Field Studies. *Management Science*, 46(2), 186-204. <https://doi.org/10.1287/mnsc.46.2.186.11926>
 36. Zahra, F. (2015) *Qatar is an emerging real estate market backed by a strong government*. Retrieved from <http://www.qatarconstructionnews.com/qatar-emerging-real-estate-market-backed-strong-government/> (accessed on December 2, 2015).