

# “Market dynamics and future prospects of the automobile industry in Saudi Arabia”

## AUTHORS

Mohammad Rumzi Tausif  <https://orcid.org/0000-0001-7485-9385>  
Mohammad Imdadul Haque  <https://orcid.org/0000-0001-6323-032X>

## ARTICLE INFO

Mohammad Rumzi Tausif and Mohammad Imdadul Haque (2018). Market dynamics and future prospects of the automobile industry in Saudi Arabia. *Problems and Perspectives in Management*, 16(4), 246-258.  
doi:[10.21511/ppm.16\(4\).2018.21](https://doi.org/10.21511/ppm.16(4).2018.21)

## DOI

[http://dx.doi.org/10.21511/ppm.16\(4\).2018.21](http://dx.doi.org/10.21511/ppm.16(4).2018.21)

## RELEASED ON

Thursday, 22 November 2018

## RECEIVED ON

Friday, 20 July 2018

## ACCEPTED ON

Wednesday, 14 November 2018

## LICENSE



This work is licensed under a [Creative Commons Attribution 4.0 International License](https://creativecommons.org/licenses/by/4.0/)

## JOURNAL

"Problems and Perspectives in Management"

## ISSN PRINT

1727-7051

## ISSN ONLINE

1810-5467

## PUBLISHER

LLC “Consulting Publishing Company “Business Perspectives”

## FOUNDER

LLC “Consulting Publishing Company “Business Perspectives”



NUMBER OF REFERENCES

40



NUMBER OF FIGURES

1



NUMBER OF TABLES

6

© The author(s) 2026. This publication is an open access article.



BUSINESS PERSPECTIVES



LLC "CPC "Business Perspectives"  
Hryhorii Skovoroda lane, 10, Sumy,  
40022, Ukraine

[www.businessperspectives.org](http://www.businessperspectives.org)

**Received on:** 20<sup>th</sup> of July, 2018

**Accepted on:** 14<sup>th</sup> of November, 2018

© Mohammad Rumzi Tausif,  
Mohammad Imdadul Haque, 2018

Mohammad Rumzi Tausif, Assistant  
Professor, Prince Sattam Bin  
Abdulaziz University, KSA.

Mohammad Imdadul Haque,  
Associate Professor, Prince Sattam  
Bin Abdulaziz University, KSA.



This is an Open Access article,  
distributed under the terms of the  
[Creative Commons Attribution 4.0  
International license](https://creativecommons.org/licenses/by/4.0/), which permits  
unrestricted re-use, distribution,  
and reproduction in any medium,  
provided the original work is properly  
cited.

Mohammad Rumzi Tausif (KSA), Mohammad Imdadul Haque (KSA)

# MARKET DYNAMICS AND FUTURE PROSPECTS OF THE AUTOMOBILE INDUSTRY IN SAUDI ARABIA

## Abstract

As the Kingdom of Saudi Arabia focuses on Vision 2030, there is an immediate need to establish some big manufacturing industries to create jobs and to generate revenue from non-oil sectors. Automobile is one such sector where demand is very high in the Kingdom. Local manufacturing can create a lot of jobs and revenue. This study tries to analyze the scope of automobile sector in the Kingdom. The objective here is to identify the functional value of cars, which can be useful for potential automobile manufacturers. A sample of population is asked about their satisfaction from cars based on five broad factors, namely safety, comfort, aesthetic, instrumentation and engine, through a recent primary survey conducted in 2018. Using structural equation modeling, the study finds that consumers in the Kingdom give maximum importance to the engine of the car. This finding would be helpful for designing the features of a local brand as per the preferences of the local market. Market dynamics indicates a strong consumer base. Future prospects are also promising, as there is strong domestic demand. This can be tapped if production is localized, leading to a development of an entire new manufacturing sector. Finally, the study discusses some feasible options for automobile manufacturing in the Kingdom.

## Keywords

customer satisfaction, specification, structural equation modeling, manufacturing

**JEL Classification** L16, L62, L78

## INTRODUCTION

Automobile is one sector where demand is very strong and the country can likely rely on it for long-term benefits. Drucker (1946) has called the automobile industry as "the industry of industries", as it has strong forward and backward linkages. The upstream linkages are metals, mining, plastics, rubber, glass, and electronics. The downstream linkages are finance, insurance, sales, service, advertising, logistics, and transportation. But, as per the 54th Annual report of Saudi Arabian Monetary Agency (SAMA), manufacturing industries as a whole, contributed only 12.16 percent to Saudi Arabia's gross domestic product (GDP). As automobile sector is in itself a part of the manufacturing sector, it is understood that there is no significant contribution from this sector, both in terms of revenue and in terms of employment.

Nevertheless, the consumer market structure looks promising in terms of demand for automobiles. Kingdom's population is approximately 31 million and is increasing at the rate of 2.3% per year. The number of households is growing at the rate of 3.7% per year. The population is affluent, with a GDP per capita of around \$24,252. Moreover, the GDP is rising at around 5%-6% a year. As per the demographic survey conducted by General Authority of Statistics (2016), approximately 92% of the households have at least a car, and over 56% households have

more than one car. Moreover, as females have been allowed to drive since September 2017, 20% of Saudi women who are about three million will be driving cars by 2020 (Arabian Business, 2018). This means a surge in demand for cars.

The researchers have observed that cars are used for a range of activities including daily commuting to schools, offices, shopping; long distance travelling and for desert safari in the Kingdom. Here cars are essential not only for transportation, but also for all instances of mobility. Options like carpooling is still not very popular in the Kingdom, according to a study conducted by Altawi (2016), about 60% of population in Tabuk region have never used car pooling, 23% have used seldom, may be just once a week. It has been reported that families have individual cars for individual family members and a big one for 'group trips' (Randheer et al., 2017).

Moreover, there are 69 cities in the Kingdom (World Population Review, 2018). At the moment, there are four major rail routes in Saudi, these routes connect about 17 cities of the Kingdom (IPFS, 2018). Also there are 33 airports in Saudi (The Airport Authority, 2018). Though there are these many airports and railway stations, still the prominent destinations that these cover are hardly more than 10. There are no metros or waterways in the Kingdom. This indicates that transportation by road would be the most common mode of transport. The cheap price of gas has largely made cars affordable for all. Good quality of roads, and law and order also make travel by road a preferred one. The roads are in admirable form and are built to endure the Kingdom's harsh climate (World Highways, 2013).

From the above discussion, it can be inferred that demand for automobiles is very high in the Kingdom. The market dynamics suggests a strong consumer base. Growing population, affluence, cultural inclinations and infrequent other means of transport makes it a good market for cars. The study now aims to look for existing studies on the automobile, particularly car market in the Kingdom.

---

## 1. LITERATURE REVIEW

The Kingdom of Saudi Arabia (henceforth referred to as Kingdom) has the second largest crude oil reserves in the world (Maqsood & Goswami, 2018). The recent downturn in the oil prices since 2012 and the deceleration of worldwide economic growth have put strain on the Kingdom's economy (Rehman, 2018). Being a predominantly oil exporting country gasoline prices have negative effects on the market performances of many sectors (Shahid et al., 2017). Towards this, the Kingdom is working on a major economic transformation plan. It is named Vision 2030. Some of the salient points of Vision 2030 are to increase non-oil government revenue, to increase private sector's contribution to GDP, to increase foreign direct investment and to reduce the rate of unemployment (Vision 2030 website). As the Kingdom focuses on Vision 2030, the economy needs to be diversified (Haque, 2016). There is a necessity to focus on those areas that can generate good revenue and employment for the Kingdom (Jawadi et al., 2018). Developing new manufacturing industries can in-

crease non-oil revenue, private and foreign investments and employment. That's how automobile manufacturing is a viable option for the Kingdom.

According to Assad (2006), Saudi Arabia is moving towards a consumer society because of global, local, economic, social and governmental forces. According to Biswas et al. (2014), technical specifications are emerging as the key factor in choosing cars. Fayad's (2014) study basically concentrated on the sales cycle in the new vehicle purchase process. It was about the vibrancy and the huge extent of the automobile market in the Kingdom. It predicted the automobile demand to be further optimistic with reference to the socio-economic aspects of the population. It even referred the Kingdom as 'holy grail' for manufacturers due to the efficiencies in cost. More importantly, it quoted from sources about instances of manufacturing of automobiles in the Kingdom. It stated that certain companies like General Automotive Manufacturing Company, Proton, Lotus and Al-Qabba Group were planning for manufacturing facilities and it reported that Isuzu Motors estab-

lished a production facility in the Kingdom. It also reported that Jaguar-Land Rover owned by Tata Motors (India) is negotiating to start manufacturing unit within the Kingdom.

Moosa and Hasan (2015) tried to identify the customer perceived value associated with automobile and examined its relation with customer satisfaction and brand loyalty. The study reported that the most important values with respect to automobiles in terms of decreasing significance were functional, emotional, epistemic and then social. Functional value had a positive influence both on consumer satisfaction and loyalty. Emotional value and social value had no impact on consumer satisfaction. This study identified functional value, which 'met consumers' requirements for product functions and quality' as the most important criteria. An area for further research would be the identification of the elements of functional value.

As per Industrial Cluster (2016), 6 items which make the Kingdom a good market for automotive manufacturing are good market, strategic location, growing economy, young population, talented local workforce, and access to raw material. It also reports that Mercedes Benz, Volvo, Isuzu Truck Assembly, and PCC Automotive Components have already become successful in manufacturing options in the Kingdom. These successes are primarily in spare parts and truck manufacturing. Toyota signed MoU with NICDP in 2017 to perform a feasibility study of making a manufacturing automobile and spares. It also aims at evaluation options of procuring local raw materials from Sabic, Maaden, Petro Rabigh, and other domestic companies.

Hassan (2017) studied the social, epistemic and conditional values related to automobiles. He found epistemic value and conditional value to be positive and significant. Social value has a negative impact on satisfaction, as it was negatively related with satisfaction and brand loyalty. Acceptance and positive word of mouth from friends, family and colleagues was important when purchasing a vehicle. That indicated that the perception of existing consumers was important. The study expressed a need for further study on the 'needs and wants' of prospective consumers.

Randheer et al. (2017) identified many positive factors for automobile manufacturing in the Kingdom. The positive factors identified by the study are: 100% FDI, 20% corporate tax and absence of other taxes, availability of local raw materials and in-shape dealership system. The study also considered the six countries of Gulf Cooperation Council (GCC) as a 'homogeneous group' because of similarities in geographical, cultural and tariff business-related rules. These six countries have an import potential of over a million cars every year. Further, the study pointed out that the Kingdom is strategically located with reference to Asia, Africa and Europe. Its 'centripetal' location can very well make it an export hub. A probable problem identified by the study was achieving the economies of scale. The study identified two solutions for it: first, concentrating only on a few specific models to meet local demands and, second, using its strategic location to become an export hub.

As per Industrial Cluster (2018), sales of light vehicles in the Kingdom were 7,740,001 units in 2015. Toyota is the leader in sales with approximately 34% market share followed by Hyundai-Kia (23%), General Motors (12%), Nissan-Renault (7%), ISUZU (4%), Ford, Honda, Mitsubishi, Mazda (2% each) and the rest (9%). Another study conducted by focus2move (2017) predicts the Kingdom's outlook as positive for the coming year. It reports that the Kingdom presently is the largest importer of vehicles and auto parts in the Middle East, with around 760,000 sales per year. It predicts the growth rate around 6.7% annually. It further predicts the growth would be more than a million by 2020.

## 2. RESEARCH PROBLEM

Based on the above review of literature, the present study plans to identify the functional value of cars with the aim of knowing the needs and wants of customers. If a car is to be manufactured inside the Kingdom, it is very important to know what the requirements of customers are. The objective of the study is to identify the factors of consumer buying behavior of Saudi car market. It will be helpful to understand how consumer is choosing a car; what factors he is giving importance to. The study would be helpful for designing the features as per the expectations and needs of the local

market. The significance of this study would be to provide a broad guideline towards the features of the car, which the prospective automobile makers in the Kingdom should take care of. It is important that instead of making different models, the first generation of automobile makers make fewer models and reap the benefits of economies of scale.

### 3. RESEARCH METHODOLOGY

The major aspiration of this study is to identify the factors that affect the consumer buying behavior in the Saudi car market. A questionnaire is proposed to be administered to a sample of the population to understand the attitude of the respondents to different aspects of cars. Ahmed et al. (2013) suggest that "Consumer belonging to different educational occupational, income and age categories reveal more or less a similar pattern in rating / ranking different factors considered for brand choice". It is planned that the questionnaire would consist of statements on safety, comfort, aesthetic, instrumentation, engine and satisfaction from the car. Each of these aspects has five questions. Respondents respond on a 5-point Likert scale with 1 being strongly agree and 5 being strongly disagree. Cronbach Alpha will be applied to measure the reliability of the questionnaire.

Structural equation modeling (SEM) is a commonly used modeling technique for behavioral sciences. Sewall Wright first used it in 1921. The theoretical constructs are represented by latent factors. The relations between these constructs are shown by path coefficients. SEM is a generalized framework that comprising "regression analysis, pathway analysis, factor analysis, simultaneous econometric equations, and latent growth curve models". Path diagrams visualize the model. It consists of box and circles linked by arrows. Box denotes observed variables and circles denote latent constructs. Single headed arrows show causal relationship. After specifying the model, the factor loadings are estimated. Chi-square test is used to check if the hypothesized model fits the data or not. A highly significant Chi-square test denotes that the model is rejected.

The unobserved variables are safety, comfort, aesthetic, instrumentation and engine. These are the latent variables. Each of the latent variables has four statements. These statements are the indicators of the latent variables. These statements are the observed variables. Finally, a relationship is established between the above five variables and satisfaction. The sample respondents are asked about their attitude towards these latent variables.

### 4. RESULTS OF THE STUDY

The questionnaire was administered to a sample of 535 respondents. However, only a total of 488 responses are taken into consideration. The remaining questionnaires are ignored due to incomplete responses. A response rate of around 91% is good for the study. The respondents are from the Al Kharj region of the Kingdom. The sample respondents constituted a mix of different age group, different employment status, different monthly incomes, preferred different types of cars, preferred cars from different country of origin, and different brands (Table 1). There were only two age categories. The first one was less than 25 years. There were 298 respondents in this group. The other category was of more than 25 years. This category had 190 respondents. Majority of the respondents (390) were of the middle income category with a monthly income of 5,001-10,000 riyals. 56 respondents have monthly salary less than 56 and 42 respondents had salary more than 10,000 riyals. The most preferred type of car is sedan, followed by SUV and pickups. The hatchbacks are the least preferred. Japanese cars were preferred the most followed by American, European and Korean.

In total, there are 30 statements in the questionnaire. There are 5 statements on each of the aspects (Table 2). The statements are ranked on a Likert scale of 1 to 5, where 1 referred to strongly agree and 5 referred to strongly disagree. For all the five items in the 'safety' criteria, the score was between 1 and 2, indicating that the respondents overall agree that safety is important. The average score is 1.71. But for the remaining criteria namely, comfort, aesthetic, instrument and engine, the average score is between 2 (agree) and 3 (neutral).

Even the average score for the 5 statements on satisfaction has a score between 2 and 3, indicating respondent's overall satisfaction from their cars.

Next, an attempt is made to study the relationship between the five features (safety, comfort, aesthetic, instrumentation, engine) of car and satisfaction from the car using structural equation modeling. Satisfaction is the dependent variable and safety, comfort, aesthetic, instrumentation, engine are the independent variables. The maximum likelihood method is used to establish relationship between the independent and the five dependent variables. First, we estimate unstandardized estimates. Out of the entire variables, only one variable, named 'Engine' is significant. Its coefficient is 0.26 and its *p*-value is 0.01 (Table 4). All the other variables, namely safety, comfort, aesthetic and instrumentation, are not significant. The result is quite unexpected, as it suggests that things like safety, comfort, aesthetic and instrumentation are not important to consumers. Only 'Engine' was having an impact on satisfaction from cars. The specifications included in the 'Engine' criteria are valve/cylinder configuration, engine displacement, maximum power and torque, transmission type and four wheel drive.

However, the probability value is significant for the Likelihood Ratio (LR) test (Table 6). This indicates that the model is not fit. The model is not fit despite the fact that all the 30 observed variables are significantly related with their respective constructs (Table 5). The internal consistency using Cronbach Alpha has a value of 0.88, which assures that the questionnaire is reliable (Table 3). A plausible reason for the model being not fit may be the non-inclusion of an important variable, that is, brand. However, the researchers have deliberately left out brand, as the idea behind this study is to identify attributes of a prospective automobile, which would be produced indigenously by the Kingdom itself.

## 5. DISCUSSION ON FUTURE PROSPECTS

The Kingdom's urge to diversify itself and the market dynamics and proper usage of the consumer preference/satisfaction could very well lead to the development of an automobile manufacturing sector. The

demand for automobiles is already high. 800,000 vehicles were imported in the Kingdom in 2016 (GaStat, 2016). As per Saudi Gazette (2018), the annual sales of automobiles in the Kingdom are almost SAR 20 billion, with about 600,000 new cars entering the market every year. This sector alone is expected to generate 100,000 additional job opportunities by 2030. Also, by 2030, contribution of automobile sector will be about SAR 50 billion of the Saudi's GDP. As per Oxford Business Group (2018), the sale of new cars in Saudi is expected to be around 1million per year by 2020. This indicates that there is a strong domestic demand which can be tapped if production can be localized.

The authors tried to find success stories of automobile manufacturing in countries other than the developed nations like US, UK, Germany, Japan, etc. Two countries have caught the attention of the authors, namely India and Malaysia. The automotive industry in India is one of the largest in the world with an annual production of 2,90,73,892 vehicles in the fiscal year 2017–2018 with an overall turnover of \$67,724 million. India is also a prominent auto exporter and has strong export growth. It exported a total of 40,40,172 cars, trucks and two wheelers in the period 2017–2018. This industry presently accounts for around 4% of the GNP and 17% of the indirect tax revenue (SIAM, 2018).

Indian automotive industry emerged in 1940s. Initially, there were only three prominent automobile companies, the government had a very conservative approach, and no foreign company was allowed to manufacture or sell cars in India. In 1980's, government formed a joint venture with Suzuki motors of Japan and a new company Maruti Suzuki was established. This company brought latest technology and design to Indian market. That was just the beginning of the Indian automobile revolution. In 1990's, government further liberalized the economy making it easy for foreign companies to invest in India. Within a short span of time, many prominent global players like GM Motors, Toyota, Nissan, Mitsubishi, Opel, Mercedes, etc. entered the Indian market. Today almost all global automobile manufacturers are present in India.

In order to safe guard the Indian investors and Indian job market, the Government of India has allowed foreign investment, but with some con-

ditions. Any manufacturer who intends to sell cars in India must manufacture his cars in India. A manufacturer cannot import cars from other countries and sell in India. In case a manufacturer imports a car and sells in India then there is an import duty of 100 percent. Further, import duty on cars has been linked to indigenization of manufacturing. The more indigenization a company does, the more relief they get in duty. In order to save this tax, most of the manufactures have established their production facilities with high level of indigenization (Custom, 2018).

Another country which caught the attention of the researchers is Malaysia. In Malaysia, automobile has been one of the top most imported items. Seeing this as an opportunity, Malaysian government formed joint venture with top Japanese companies and launched their own automobiles. Two main projects were launched namely Perusahaan Otomobil Nasional (PROTON) in 1983 and Perusahaan Otomobil Kedua (PERODUA) in

1993. These two local companies have launched a number of car models in Malaysia. Today, these two companies hold 90% of Malaysian car market, and other 25 companies have just 10% share (MAI, 2018). Presently, Malaysia has a strong automotive ecosystem with over 25 vehicle manufacturers and assemblers, 600 local vendors and 50,000 after market establishments, supporting more than 600,000 jobs (MAI, 2018).

The Malaysian model is not without limitations. One major problem with Malaysian automotive policy is the failure of the companies to become global players. The automotive industry in Malaysia largely caters to the domestic demand. The Malaysian automotive policy has been successful only because of the protectionist policy being adopted by the government. There is huge price gap between domestic and global brand. It is argued that Malaysian cars are not at par with global standards. That is the reason Malaysian cars have failed outside Malaysia (Lim, 2017).

---

## CONCLUSION

Automobile manufacturing can fulfill the economic vision of the Kingdom. As the product satisfies the needs of the local customer, it will definitely be a success. The outcomes of this study clearly show that Saudi customers give lot of importance to engine of the car. This may be due to long distances they have to drive and many customers take their cars to deserts, so they need good and powerful engines. Aesthetic is not a factor to which customers have given significant importance. This may be because of a simple reason that cars here in the Kingdom are a thing of necessity and not necessarily a fashion statement. Safety also has not scored very high in this study. This may be because most respondents feel something obvious and it has to be there. Most of the respondents have not given importance to inside cluster. The decision of buying or not buying a car may not be based on cluster.

One very important factor that has not been emphasized in this study is brand. It has not been attended intentionally, because there is no local brand is available as of now. There is no sense of asking people to compare a local brand with global brands. However, the brand could be a big factor in decision-making. In addition, a local manufacturer will have to give a lot of importance to this factor. This problem can be solved by having a joint venture with an international brand. The Kingdom can take lead in becoming the first Arab nation to have its own car. It can be a big step in moving the economy towards non fuel-based industries. Further, even if the Saudi brand does not become a popular brand abroad, it is still a win-win situation. The reason for this is the Kingdom itself has a big domestic market.

The Government can take steps to encourage local businesspersons to establish an automobile brand of their own or can encourage major global manufacturer to establish his manufacturing base in the Kingdom. Taxation of the companies can be linked to level of Saudization in the production. Here Saudization will stand for amount of local component used in the production. If a car is imported with 0% Saudization, that is, with no local component, tax should be the highest then. In case of 70% Saudization, less tax and for 50% Saudization, the tax rate would be further lower. If a car is manufac-

tured with 100% local components, then it may be given additional benefits apart from reduced taxation. This policy could lead to manufacturers establishing their manufacturing units in the Kingdom, which will create revenue and employment in the manufacturing sector.

## ACKNOWLEDGEMENT

The authors thank the Deanship of Scientific Research, Prince Sattam Bin Abdulaziz University, Saudi Arabia, for providing financial support to complete this research (Project number: 2017/02/7554).

## REFERENCES

- Ahmed, M., Zaman, F., Irfan, M. S. (2013). Consumer's Brand Choice Behavior For Car. *Kuwait Chapter of Arabian Journal of Business and Management Review*, 2(5), 198-204. Retrieved from [https://www.arabianjbm.com/pdfs/KD\\_VOL\\_2\\_5/19.pdf](https://www.arabianjbm.com/pdfs/KD_VOL_2_5/19.pdf)
- The Airport Authority (2018). *List of all airports in Saudi Arabia*. Retrieved from <https://airport-authority.com/browse-sa>
- Alkhateeb, T. T. Y., Mahmood, H., Sultan, Z. A., & Ahmad, N. (2017). Financial market development and employment nexus in Saudi Arabia. *International Journal of Applied Business and Economic Research*, 15(21), 165-174. Retrieved from [https://www.researchgate.net/publication/322381602\\_Financial\\_market\\_development\\_and\\_employment\\_nexus\\_in\\_Saudi\\_Arabia](https://www.researchgate.net/publication/322381602_Financial_market_development_and_employment_nexus_in_Saudi_Arabia)
- Arabian Business (2018). *Saudi women to transform kingdom's automotive industry*. Retrieved from <https://www.arabianbusiness.com/culture-society/391881-saudi-women-to-transform-kingdoms-automotive-industry>
- Assad, S. W. (2006). Facing the Challenges of Consumerism in Saudi Arabia. *King Saud University Press Arts*, 19(1), 1-20. Retrieved from <https://ksupress.ksu.edu.sa/En/Pages/IssueArticles.aspx?JournalID=323>
- Attiyah Al-Atawi (2016). Sustainable travel modes in Saudi Arabia: is there a potential for formal car-sharing scheme? *World Journal of Science. Technology and Sustainable Development*, 13(1), 46-55. <https://doi.org/10.1108/WJSTSD-10-2015-0052>
- Custom (2018). *Society of Indian Automobile Manufacturing*. Retrieved from <http://www.siamindia.com/economic-affairs.aspx?mpgid=16&pgid1=18&pgidtrail=20>
- Drucker, P. (1946). *The Concept of the Corporation*. John Day, New York. Retrieved from <https://www.cambridge.org/core/journals/review-of-politics/article/corporation-in-the-industrial-society-peter-f-drucker-concept-of-the-corporation-new-york-the-john-day-company-1946-ppix-and-297-300/601D5E95882-7256B3297F434D011B61D>
- Fadye Saud Al Fayad (2014). Examining the Broken Sales-Cycle in the Saudi Arabia Automotive Market international. *Journal of Business and Management*, 9(8), 41-50. Retrieved from <http://www.ccsenet.org/journal/index.php/ijbm/article/download/36839/21581>
- Focus2move (2017). *Saudi Arabia outlook is positive for 2017*. Retrieved from <http://focus2move.com/saudi-arabia-automotive/>
- GASTAT (2016). *Vehicles Imported by Model from 2012 to 2016 A.D*. Retrieved from <https://www.stats.gov.sa/en/6070>
- General Authority of Statistics (2016). *Demographic survey*. Retrieved from [https://www.stats.gov.sa/sites/default/files/en-demographic-research-2016\\_2.pdf](https://www.stats.gov.sa/sites/default/files/en-demographic-research-2016_2.pdf)
- Haque, M. I. (2016). Cointegration and Causality between Economic Growth, Government Sector and Private Sector in Saudi Arabia. *International Journal of Applied Business and Economic Research*, 14(12), 8545-8561. Retrieved from <http://www.serialsjournals.com/serialjournalmanager/pdf/1484113754.pdf>
- IndexMundi (2018, January, 20). *Saudi Arabia Labor force – by occupation*. Retrieved from [https://www.indexmundi.com/saudi\\_arabia/labor\\_force\\_by\\_occupation.html](https://www.indexmundi.com/saudi_arabia/labor_force_by_occupation.html)
- Industrial Clusters (2018). *Automotive, NICPD*. Retrieved from <https://www.ic.gov.sa/media/1138/auto-report.pdf>
- Industrial Cluster (2016). *Saudi Arabia Auto Cluster*. NICPD.
- Industrial Clusters (2018). *Automotive*. Retrieved from <https://www.ic.gov.sa/en/clusters/automotive/overview/>
- Jawadi, F., Jawadi, N., & Cheffou, A. I. (2018). Toward a new deal for Saudi Arabia: oil or Islamic stock market investment? *Applied Economics*, 50(59), 6355-6363. <https://doi.org/10.1080/00036846.2018.1486018>
- Khamis, R., Anasweh, M., & Hamdan, A. (2018). Oil prices and stock market returns in oil exporting countries: Evidence from Saudi Arabia. *International Journal of Energy Economics and Policy*, 8(3), 301-306. Retrieved from <http://www.econjournals.com/index.php/ijeeep/article/view/6541>
- Kokku Randheer, Heba U. Trabulsi, Hala A. Al Ajmi, & Hessah K. Al Jasser (2017). Emerging Industry: A Case of Automobile Manufacturing in Saudi Arabia. *Journal of Marketing Research and Case Studies*. <https://doi.org/10.5171/2017.799336>
- Lim, A. (2017). *Holistic growth for automotive industry in 2017 – MAI*.

- Driven Communications*. Archived from the original on 19 May 2017. Retrieved 20 May, 2017 from <https://paultan.org/2017/01/21/holistic-growth-for-automotive-industry-in-2017-mai/>
22. IPFS (2018). *List of railway stations in Saudi Arabia*. Retrieved November, 2018 from [https://ipfs.io/ipfs/QmXoyypizjW3WknFi-JnKLwHCnL72vedxjQkDDP1mX-Wo6uco/wiki/List\\_of\\_railway\\_stations\\_in\\_Saudi\\_Arabia.html](https://ipfs.io/ipfs/QmXoyypizjW3WknFi-JnKLwHCnL72vedxjQkDDP1mX-Wo6uco/wiki/List_of_railway_stations_in_Saudi_Arabia.html)
  23. Mahmood, H., & Alkahtani, N. S. (2018). Human resource, financial market development and economic growth in Saudi Arabia. *A role of human capital Economic Annals-XXI*, 169(1-2), 31-34.
  24. MAI (2018). *History of Malaysia's Automotive Industry*. Malaysian Automotive Institute. Retrieved from [http://mai.org.my/v5test/index.php?option=com\\_content&view=article&id=31&Itemid=181&lang=en](http://mai.org.my/v5test/index.php?option=com_content&view=article&id=31&Itemid=181&lang=en)
  25. Malaysia Automotive Institute's (MAI) (2017, November 6). *Motor vehicle sector is on track to contribute 10% to (GDP) in 2020*. Retrieved from <https://www.thestar.com.my/business/business-news/2017/11/06/motor-vehicle-sector-set-to-contribute-10pc-to-gdp/>
  26. Mohanty, S. K., Onochie, J., & Alshehri, A. F. (2018). Asymmetric effects of oil shocks on stock market returns in Saudi Arabia: evidence from industry level analysis. *Review of Quantitative Finance and Accounting*, 51(3), 595-619. <http://dx.doi.org/10.1007/s11156-017-0682-5>
  27. Moosa, M. Y., & Hassan, Z. (2015). Customer Perceived Values associated with Automobile and Brand Loyalty. *International Journal of Accounting, Business and Management*, 3(1), 99-115. Retrieved from [https://papers.ssrn.com/sol3/papers.cfm?abstract\\_id=2941363](https://papers.ssrn.com/sol3/papers.cfm?abstract_id=2941363)
  28. Namrata (2015, July 7). 1.5 cr people to be employed in automobile sector by 2022. *The Times of India*. Retrieved from <https://timesofindia.indiatimes.com/business/india-business/1-5-cr-people-to-be-employed-in-automobile-sector-by-2022/article-show/47977138.cms>
  29. PTI (2017, May 18). *Auto sector may contribute 12 per cent to India's GDP in next decade*. Retrieved from <https://economictimes.indiatimes.com/industry/auto-sector-may-contribute-12-per-cent-to-indias-gdp-in-next-decade-anant-geete/article-show/58736673.cms>
  30. Rehman, M. Z. (2018). Banking sector development, stock market development and economic growth evidence from Saudi Arabia. *Academy of Accounting and Financial Studies Journal*, 22(4), 15. Retrieved from [https://www.researchgate.net/publication/327847428\\_Banking\\_sector\\_development\\_stock\\_market\\_development\\_and\\_economic\\_growth\\_evidence\\_from\\_Saudi\\_Arabia](https://www.researchgate.net/publication/327847428_Banking_sector_development_stock_market_development_and_economic_growth_evidence_from_Saudi_Arabia)
  31. Saudi Gazette (2018, Oct. 30). *Saudi automotive sector logs SR20b yearly sales*. Retrieved from <http://saudigazette.com.sa/article/515093/BUSINESS/Saudi-automotive>
  32. Senan, N. A. M., Mahmood, H., & Liaquat, S. (2018). Financial markets and electricity consumption nexus in Saudi Arabia. *International Journal of Energy Economics and Policy*, 8(1), 12-16. Retrieved from [https://www.researchgate.net/publication/322919751\\_Financial\\_markets\\_and\\_electricity\\_consumption\\_nexus\\_in\\_Saudi\\_Arabia](https://www.researchgate.net/publication/322919751_Financial_markets_and_electricity_consumption_nexus_in_Saudi_Arabia)
  33. Shahid, H. Mahmood, F. Usman, M. (2017). Effects of gasoline price changes on short term market behaviour of energy and non-energy sector: Evidence from Saudi Arabia. *International Journal of Energy Economics and Policy*, 7(4), 283-286. Retrieved from <https://www.econjournals.com/index.php/ijeep/article/viewFile/5319/3249>
  34. SIAM (2018). *Performance of Auto Industry during 2017-18*. Retrieved from <http://www.siamindia.com/statistics.aspx?mpgid=8&pgidtrail=9>
  35. Syed, A. M., Bajwa, I. A. (2018). Earnings announcements, stock price reaction and market efficiency – the case of Saudi Arabia. *International Journal of Islamic and Middle Eastern Finance and Management*, 11(3), 416-431. Retrieved from <https://www.scopus.com/inward/record.uri?eid=2-s2.0-85042-594665&doi=10.1108%2fIMEFM-02-2017-0044&partnerID=40&md5=da5bd4cf24c2572db595d3e4efc1c464>
  36. Vision 2030 (n.d.). Retrieved November, 2018 from <http://vision2030.gov.sa/en/goals>
  37. Wiley, A. M. (2017, November 6). *Auto sector to contribute 10% to GDP by 2020*. Retrieved from <http://www.theedgemarkets.com/article/auto-sector-contribute-10-gdp-2020-%E2%80%94-mai>
  38. World Highways (2013). *Saudi Arabian Capital Riyadh Benefiting from Major Transport Investment*. Retrieved from <http://www.worldhighways.com/sections/key-projects/features/saudi-arabian-capital-riyadh-benefiting-from-major-transport-investment/>
  39. World Population Review (2018). *Population of Cities in Saudi Arabia*. Retrieved from <http://worldpopulationreview.com/countries/saudi-arabia-population/cities/>
  40. Zubair, H. (2017). Impact of Social, Epistemic and Conditional Values on Customer Satisfaction and Loyalty in Automobile Industry: A Structural Equation Modeling. *Journal of Marketing and Consumer Behaviour in Emerging Markets*, University of Warsaw, Faculty of Management, 1(5), 29-44. Retrieved from <https://ideas.repec.org/a/sgm/jmcbem/v1i5y2017p29-44.html>

## APPENDIX

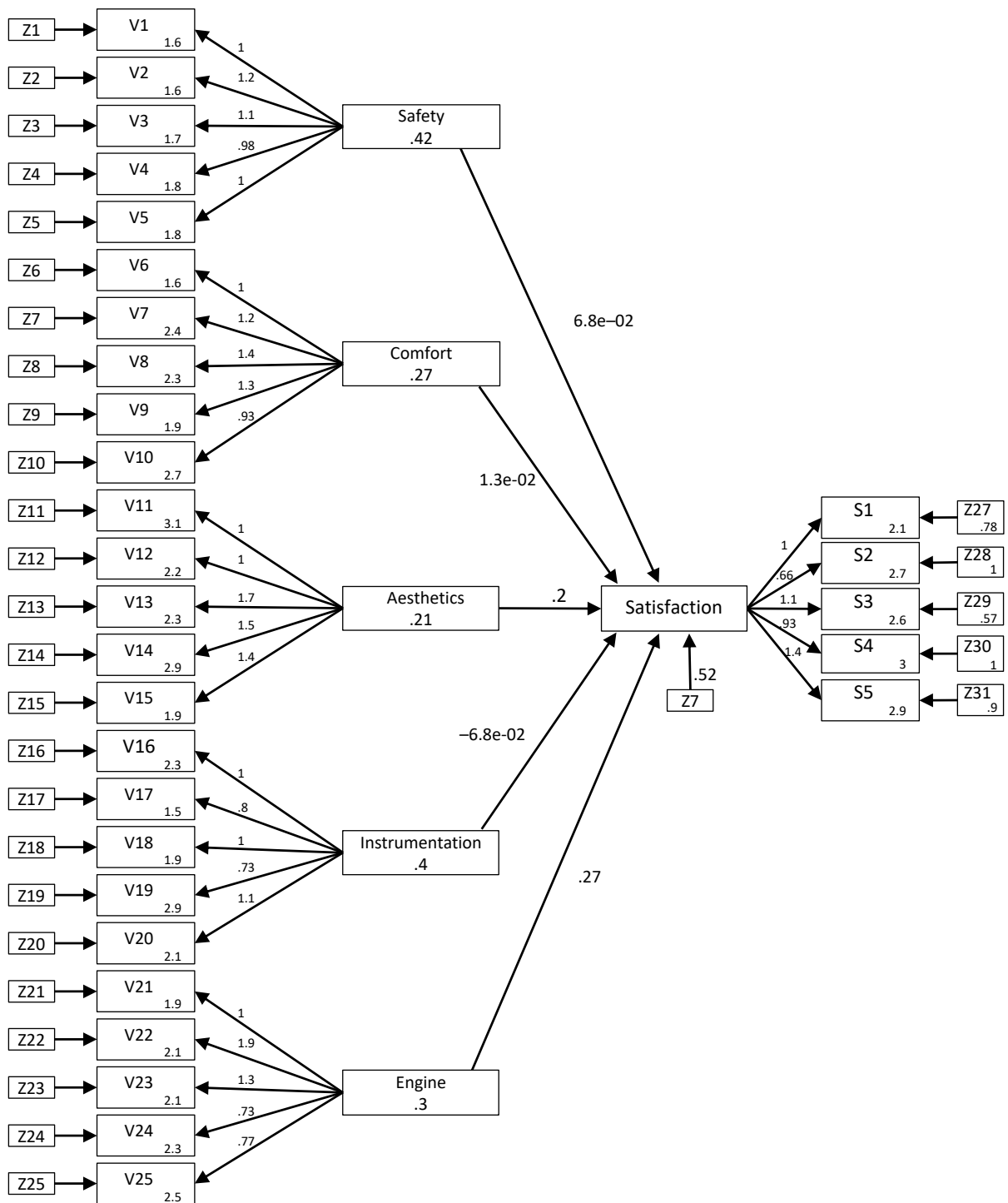

Figure 1. Structural equation modeling

**Table 1.** Demographic features of the respondents

<b>Age</b>	
Less than 25	298
More than 25	190
<b>Employment status</b>	
Government employee	82
Private employee	23
Others	383
<b>Monthly income</b>	
Less than, 5000	56
5,001-10,000	390
More than 10000	42
<b>Preferred car</b>	
Sedan	207
ESUV	153
Hatchback	11
Pickup	46
Others	71
<b>Car from preferred country</b>	
American	138
European	68
Japanese	215
Korea	54
Others	13
<b>Brand</b>	
Ford	73
Chevrolet	105
Toyota	132
Nissan	58
Hyundai	63
BMW	24
Mercedes	23
Others	10
<b>My car was</b>	
Purchased by me	198
Got it from family or company	290

**Table 2.** Descriptive statistics of the statements

No	Description	Mean	Std. Deviation
<b>Safety</b>			
V1	Airbags for all passengers is important	1.56	0.99
V2	Tire Pressure Monitoring System (TPMS) is important	1.61	0.93
V3	Seat belt warning features for seat belts and door ajar, etc. care important	1.70	1.04
V4	Anti-Lock Braking System (ABS)/Traction Control System (TC/TCS) are important	1.83	1.04
V5	Sensors and parking camera are important	1.81	1.04
<b>Comfort</b>			
V6	Rear AC vents and control are important	1.59	0.94
V7	Keyless entry/Button start/central locking are important	2.40	1.17
V8	Cruise control is important	2.27	1.17
V9	Power steering, power windows and steering adjustment are important	1.90	1.09
V10	Refrigerator is important	2.67	1.19
<b>Aesthetics</b>			
V11	Leather seat upholstery is important	3.06	1.18
V12	Cabin lamps, glove box lamp and lights on vanity mirrors are important	2.25	1.08
V13	Color of the vehicle is important	2.31	1.11
V14	Sunroof/moonroof is important	2.90	1.18
V15	Design of the vehicle is important	1.92	0.99
<b>Instrumentation</b>			
V16	Digital trip meter and tachometer, etc. are important	2.27	1.10
V17	Engine heat indicator, low fuel level warning, etc. are important	1.49	0.92
V18	Advanced music system with Bluetooth, USB, and navigation, etc. are important	1.90	1.03
V19	Display screen for rear passengers is important	2.89	1.17
V20	Steering mounted controls is important	2.08	1.07
<b>Engine</b>			
V21	Valve/cylinder (configuration) is important	1.86	1.00
V22	Displacement (cc) is important	2.11	1.04
V23	Max power and torque is important	2.07	1.04
V24	Transmission type is important	2.28	1.01
V25	Four wheel drive is important	2.48	1.20
<b>Satisfaction</b>			
S1	Overall I am satisfied with the performance of my vehicle	2.14	1.16
S2	My future purchase decision will not be affected by increase in the price of my car	2.69	1.14
S3	I would recommend my car to others	2.59	1.14
S4	If I have to purchase another car, I would purchase the same brand	2.99	1.23
S5	The car I have, is my desired car	2.88	1.41

**Table 3.** Reliability statistics

Reliability statistics		
Cronbach Alpha	Cronbach Alpha based on standardized items	No of items
0.885	0.890	30

**Table 4.** Output sheet from Stata

Variables	Coef.	Std. Err.	z	P >  z	[95% conf. interval]	
Safety	0.0680173	0.0811323	0.84	0.402	-0.0909991	0.227034
Comfort	0.0126667	0.1218931	0.10	0.917	-0.2262394	0.251573
Aesthetics	0.196998	0.138193	1.43	0.154	-0.0738554	0.467851
Instrumentation	-0.0680106	0.1114373	-0.61	0.542	-0.2864238	0.150403
Engine	0.2662016	0.1046161	2.54	0.011	0.0611579	0.471245

**Table 5.** Output sheet from Stata (measurement)

No	Measurement	Coef.	Std. Err.	z	P >  z	[95% conf. interval]	
V1	Safety			1 (constrained)			
	_cons	1.558522	0.0448975	34.71	0.000	1.470524	1.646519
V2	Safety	1.159963	0.0862827	13.44	0.000	0.9908521	1.329074
	_cons	1.605749	0.0421972	38.05	0.000	1.523045	1.688454
V3	Safety	1.159963	0.0862827	13.44	0.000	0.9908521	1.329074
	_cons	1.698152	0.0473006	35.9	0.000	1.605445	1.790859
V4	Safety	0.97748	0.0879947	11.11	0.000	0.8050135	1.149946
	_cons	1.827515	0.0471614	38.75	0.000	1.735081	1.91995
V5	Safety	1.026697	0.0898025	11.43	0.000	0.8506877	1.202707
	_cons	1.811088	0.0473002	38.29	0.000	1.718382	1.903795
V6	Comfort			1 (constrained)			
	_cons	1.593429	0.0425551	37.44	0.000	1.510023	1.676836
V7	Comfort	1.184677	0.1594435	7.43	0.000	0.8721732	1.49718
	_cons	2.396304	0.0528528	45.34	0.000	2.292714	2.499894
V8	Comfort	1.418835	0.1738158	8.16	0.000	1.078162	1.759508
	_cons	2.271047	0.0527614	43.04	0.000	2.167637	2.374458
V9	Comfort	1.253139	0.1545634	8.11	0.000	0.9502003	1.556078
	_cons	1.895277	0.0495228	38.27	0.000	1.798214	1.99234
V10	Comfort	9295697	0.1451335	6.4	0.000	0.6451132	1.214026
	_cons	2.667351	0.0539424	49.45	0.000	2.561626	2.773076
V11	Aesthetics			1 (constrained)			
	_cons	3.057495	0.0532453	57.42	0.000	2.953136	3.161854
V12	Aesthetics	1.018385	0.1746758	5.83	0.000	0.6760264	1.360743
	_cons	2.24846	0.0489782	45.91	0.000	2.152464	2.344455
V13	Aesthetics	1.685704	0.2707975	6.22	0.000	1.154951	2.216457
	_cons	2.314168	0.0500847	46.21	0.000	2.216004	2.412333
V14	Aesthetics	1.4603	0.2164552	6.75	0.000	1.036055	1.884544
	_cons	2.895277	0.0534536	54.16	0.000	2.79051	3.000044
V15	Aesthetics	1.369208	0.229201	5.97	0.000	0.919982	1.818433
	_cons	1.917864	0.0447391	42.87	0.000	1.830177	2.005552
V16	Instrumentation			1 (constrained)			
	_cons	2.268994	0.0497819	45.58	0.000	2.171423	2.366565
V17	Instrumentation	0.7960085	0.1003439	7.93	0.000	0.5993381	0.9926788
	_cons	1.494867	0.0418678	35.7	0.000	1.412807	1.576926

**Table 5 (cont.).** Output sheet from Stata (measurement)

No	Measurement	Coef.	Std. Err.	z	P >  z	[95% conf. interval]	
V18	Instrumentation	1.030713	0.1176517	8.76	0.000	0.8001205	1.261307
	_cons	1.901437	0.0467915	40.64	0.000	1.809728	1.993147
V19	Instrumentation	0.7305049	0.1076644	6.79	0.000	0.5194865	0.9415233
	_cons	2.887064	0.0529435	54.53	0.000	2.783296	2.990831
V20	Instrumentation	1.120321	0.1199911	9.34	0.000	0.8851427	1.355499
	_cons	2.078029	0.0484632	42.88	0.000	1.983043	2.173015
V21	Engine			1 (constrained)			
	_cons	1.86037	0.0452913	41.08	0.000	1.7716	1.949139
V22	Engine	1.470143	0.1533139	9.59	0.000	1.169653	1.770633
	_cons	2.106776	0.0472925	44.55	0.000	2.014085	2.199468
V23	Engine	1.287338	0.1347751	9.55	0.000	1.023184	1.551492
	_cons	2.073922	0.0470642	44.07	0.000	1.981678	2.166166
V24	Engine	0.7763789	0.1082491	7.17	0.000	0.5642146	0.9885432
	_cons	2.275154	0.045691	49.79	0.000	2.185601	2.364707
V25	Engine	0.7710026	0.1272928	6.06	0.000	0.5215133	1.020492
	_cons	2.476386	0.0541518	45.73	0.000	2.37025	2.582522
S1	Satisfaction			1 (constrained)			
	_cons	2.143737	0.0524595	40.86	0.000	2.040918	2.246556
S2	Satisfaction	0.6599794	0.0812126	8.13	0.000	0.5008057	0.819153
	_cons	2.691992	0.0513915	52.38	0.000	2.591266	2.792717
S3	Satisfaction	1.132667	0.0906454	12.5	0.000	0.9550053	1.310329
	_cons	2.587269	0.0514525	50.28	0.000	2.486424	2.688114
S4	Satisfaction	0.9265379	0.0974944	9.5	0.000	0.7354525	1.117623
	_cons	2.985626	0.0557868	53.52	0.000	2.876286	3.094966
S5	Satisfaction	1.383658	0.1183783	11.69	0.000	1.151641	1.615676
	_cons	2.876797	0.063502	45.3	0.000	2.752335	3.001258

Notes: Endogenous variables

Measurement: V1, V2, V3, V4, V5, V6, V7, V8, V9, V10, V11, V12, V13, V14, V15, V16, V17, V18, V19, V20, V21, V22, V23, V24, V25, S1, S2, S3, S4, S5. Latent: Satisfaction. Exogenous variable. Latent: safety, comfort, aesthetics, instrumentation, engine

**Table 6.** Model fit

Fit statistic	Value	Description
<b>Likelihood ratio</b>		
chi2_ms(400)	2384.502	Model vs. saturated
p > chi2	0.000	–
chi2_bs(435)	5086.973	Baseline vs. saturated
p > chi2l	0.000	–
<b>Population error</b>		
RMSEA	0.101	Root mean squared error of approximation
90% CI, lower bound	0.000	–
upper bound	.	–
pclose	.	Probability RMSEA <= 0.05
<b>Information criteria</b>		
AIC	41419.135	Akaike's information criterion
BIC	41817.02	Bayesian information criterion
<b>Baseline comparison</b>		
CFI	0.573	Comparative fit index
TLI	0.536	Tucker-Lewis index
<b>Size of residuals</b>		
SRMR	0.199	Standardized root mean squared residual
CD	0.999	Coefficient of determination