

# “Improvement of financial tools for expansion of opportunities for innovative activity investment”

## AUTHORS

Andrey Nechaev  
Ekaterina Kichkina

## ARTICLE INFO

Andrey Nechaev and Ekaterina Kichkina (2014). Improvement of financial tools for expansion of opportunities for innovative activity investment. *Problems and Perspectives in Management*, 12(4-1)

## RELEASED ON

Wednesday, 19 November 2014

## JOURNAL

"Problems and Perspectives in Management"

## FOUNDER

LLC “Consulting Publishing Company “Business Perspectives”



NUMBER OF REFERENCES

0



NUMBER OF FIGURES

0



NUMBER OF TABLES

0

© The author(s) 2025. This publication is an open access article.

Andrey Nechaev (Russia), Ekaterina Kichkina (Russia)

## Improvement of financial tools for expansion of opportunities for innovative activity investment

### Abstract

*Purpose:* In the territory of the Russian Federation the securities market carries out a role of the economic regulator and promotes integration of the economy into the world economic system. The main goal of the article is the development of the complex innovative financial tools of the derivatives use for the development of the venture business by means of the participation of the Russian venture funds. *Methods:* in the course of research methods of the comparative analysis, a statistical method, and also the econometric methods are used. *Results:* the algorithm of the innovative company interaction with the venture fund by means of the derivatives is offered in the article. This algorithm allowing to increase significantly the current assets of the innovative company and to track the received financial result from the application of derivatives. The complex algorithm of the reinvestment by derivatives creates the main forms of financing of the innovative activity with the direct participation of the venture fund. The system of the consecutive hedging by the financial instruments the risks arising at the different stages of the innovations life cycle is developed. The mathematical model is developed on the financial result calculation receiving while using the derivatives at the stages of the innovative product life cycle allowing to hedge the possible risks of the venture company. *Conclusion:* The implementation of the researches on the problem connected with the development of the innovative financial tools of the derivatives use for the development of a venture business allows formulating the set of the generalizations and conclusions.

**Keywords:** financial tools, enterprises innovative activity, venture fund, derivative.

**JEL Classification:** O10.

### Introduction

The securities market is the most important component of the financial market. The enterprises financing, venture projects, the attraction of the borrowed funds by the organizations of the various forms of ownership are carried out in the majority via tools of the stock market. In the modern economy the securities market is responsible for the problem of the capital redistribution to the spheres and branches of the economy which provide the effective development of the country in general.

The derivative financial instruments (derivatives) play the important role in the securities market. The futures and options are listed actively for a long time at the exchanges worldwide.

The banks, hedge funds, trust management and pension funds place the part of their means in the stocks and their production tools: futures, options and so forth daily.

With development of the world economy the need for the similar market mechanisms of the financial means use was caused by the capitalization of the background market every year. Not to use the derivatives in the work means intentionally to underestimate the potential opportunities put into the idea of these tools creation.

The domestic large and medium-sized enterprises starting the way on stock market today will be able to build the long-term, comprehensive programs of

the financing, with the use of many types of debt and share tools with the simultaneous circulation of the financial products in Russia and abroad tomorrow. This financing is already cheaper than the credits now.

The creation of the attractive investment climate and the increase of the innovative activity in our country is the most important and paramount task. Especially it is important in the venture business where there are the increased financial risks. The main organization rendering the assistance to the innovative companies through the acquisition of their securities are venture funds. Now these funds build the relationship with the innovative companies through the acquisition of such financial instruments as: stocks, the bonds and the bills, without using in their relationship the derivative financial instruments at all.

This fact affects the reduction of the assets turnover speed, the reduction of the liquidity and reduction of free funds of the innovationally focused companies.

In our opinion, the exit from this situation should be looked for in the use of the derivatives issued by the innovative companies and their inclusion in the relationships with the federal and regional venture funds.

*Hypothesis: proposed financial instrument will provide further investment activity of innovative companies and reduce possible risks.*

Thus, actual task is the development of the innovative financial tools of the derivatives use for the development of the venture business by means of the Russian venture funds participation.

## 1. Analysis of recent researches and publications

The various aspects of innovations, the innovative activity of the enterprises, the innovative development in general are considered in the works of Drucker, P.F. (1985), Yakovets, Y. (1999), Porter, M. (1985), Shumpeter, J.A. (1961).

The financing of innovation activities of enterprises is considered in works Nechaev, A.S. (2012, 2013), Raevsky, S.V., (2006), Folomev, A., Revazov, V. (2001). But in the existing works are poorly studied the directions of investment for stimulation of the enterprises innovative activity.

Analysis of the economic literature shows that, in contrast to Russia, economic and legal problems of the development of derivatives abroad is an extensive literature. This suggests that the use of derivatives in foreign countries is widespread and has a long tradition.

## 2. Algorithm of interaction of the innovative company with venture fund by means of derivatives

The venture funds are the investment companies working only with the innovative enterprises and projects (startups). The venture funds carry out the investments into securities or the enterprises with high or relatively high risk waiting for extremely high profit. Usually such investments are carried out in the sphere of the latest scientific development or high technologies. As a rule, 70-80% of projects do not bring any return but the profit on the remained 20-30% pays back all losses.

We offer the use of the venture funds not only for the valuable papers acquisitions but also for the acquisition of the securities derivatives (derivatives). The sequence of the innovative company actions on a basis of the higher listed derivatives looks as follows (Figure 1, see Appendix):

1. (Warrant). The venture fund gets the certificate granting the right to buy a package of securities at the fixed price in the due time before their release in the circulation from the newly created innovative company.
2. (Depository receipt). The innovative company places for the storage in credit institution securities and having received the depository receipt, certifying their existence, can receive assets at the venture fund as the proof of this document.
3. (Forward contract). Under this contract the innovative company undertakes to the time determined by the contract to transfer the basic

asset (securities) to the venture fund and the last undertakes to accept and pay it.

4. (Future contract). Under this contract the innovative company undertakes to the time determined by the contract to transfer the basic asset (securities) to the venture fund and the last undertakes to accept and pay it, thus, incurring the obligations to the exchange up to its execution, carrying out this process through a broker and dealer company.
5. (Credit default swap). The credit institution makes contributions to the venture fund which assumes the obligation to extinguish the credit which was given out the credit establishment to the innovative company.
6. (Percentage swap). The agreement between the innovative company and venture fund on the exchange of the percentage payments for the determined stipulated conditional sum in advance, i.e. the contract for the exchange of one security for another for the purpose of the overcoming of the repayment period (for example, the exchange of the medium-term bond for long-term one) which in due time the innovative company realized to the venture fund.
7. (Investment certificate). The innovative company gets an investment share at an investment fund which can be realized further (mortgaged) to a venture fund.
8. (Contract of insurance). The venture fund for the neutralization of the risks connected with the derivatives acquisition can insure it having signed the insurance contract with an insurance company.
9. (Contract of purchase or sale of derivatives). The venture fund can exercise the further sale of the derivatives to the third-party investors.

The algorithm of the interaction of the innovative company with the venture fund by means of the derivatives allows increasing significantly the current assets of the innovative companies and involving the additional contractors (credit institutions, insurance companies, investment funds, and broker and dealer companies, the exchanges) to reduce the arising risks while using the derivative financial instruments.

## 3. Complex algorithm of reinvestment by derivatives of the main forms of innovative activity financing

Let's develop the complex algorithm of the reinvestment of the financing main forms by the derivatives which will allow to level the arising debt owing to the application: factoring, leasing, forfeiting, franchising, rent, credit, overdraft,

investment tax credit, letter of credit; at first the issue of securities and then on their basis by the derivative financial instruments (Fig. 2, see Appendix).

1. At the first stage there is a formation of the debt owing to the application of such forms of financing by the innovative companies as: factoring, leasing (short-term and long-term), forfeiting, franchising, rent (short-term and long-term), credit (short-term and long-term), overdraft, investment tax credit and letter of credit (uncovered). The use of these financing forms allows the innovative companies to increase the non-current assets of the capitalized production (fixed assets, intangible assets), current assets (materials, stocks and finished goods), and free money and to reduce the tax payments.
2. At the second stage there is an issue of the corresponding securities such as: simple and double warehouse certificates, actions, bonds, bills and consignments, for clearing of those types of the debt which were formed at the first stage.
3. At the third stage the innovative company with direct participation of the venture fund begins selling of the issued derivatives created on the basis of securities at the previous stage. Namely: forward and future contracts, warrants, credit default and percentage swaps, depository receipts.
4. At the fourth stage it is possible to calculate the definite financial result aiming to the neutralization of the initial debt which arose at the first stage by the derivatives used at the third stage of this complex algorithm.

Thus, this complex algorithm of leveling the debt by the issue of securities and applications of derivatives, owing to the use of the financing various forms will be carried out with the direct participation of the venture fund what will allow increasing the current assets of the innovative company significantly.

Let's formulate a new definition which can characterize the process connected with the financing of the innovations by means of the derivative financial instruments.

The financing of innovations by means of the derivatives is the use of derivative financial instruments such as: forward and futures, warrant, credit default and percentage swap, depository receipt; created on the basis of basic assets, such as: simple and double warehouse certificate, action, bond, bill and consignment; for their realization to a venture fund for the purpose of increasing the

released money directed to the financing of the venture companies innovations.

#### **4. System of consecutive hedging the risks arising at different stages of life cycle innovations by financial instruments**

The need in the creation of these financial tools is caused by the existing problems arising at different stages of life cycle of innovations. Namely:

1. Shortage of monetary resources at a stage of an innovative product development;
2. Attraction of additional financial resources due to the additional issue of shares bringing further to possible loss of a controlling stake due to "washing out of a property share";
3. Rise in price of the materials and the accessories bought from suppliers at different stages of life cycle of the innovative production creation and realization;
4. Falling of the price for the realizing innovative production.

Thus, the life cycle of an innovation represents the set of the interconnected processes and stages of the innovation creation. The life cycle of an innovation is defined as the period from the initiation of an idea up to the removal from the production of the innovative product realized on its basis.

Let's present the generalized life cycle of the innovative production (IP) with breakdown for the following stages:

1. Stage of an IP development. At this stage the volume of the expenses connected with the development of a production and the release of new goods party that results in high prime cost of an innovative production and the underutilization of the capacities in full.
2. Stage of production start and beginning of an IP sales. At this stage there is a slow and dragged-out in a time process of the volumes accumulation of the innovative production release.
3. Stage of an IP active realization. At this stage there is a steady growth of the release volumes and the innovative production sales conducting to the greatest possible utilization of the capacities.
4. Stage of the decrease in volumes of an IP realization. At this stage there is an essential falling of the innovative product realization and respectively both decrease in the utilization of capacities and the reduction of commodity stocks. It leads to the curtailment of production and a product leaving from the market.

5. Stage of a new IP development. At this stage there is a development of the new type of an innovative product leading to the maximum increase in costs per a unit of production.

Further in Fig. 3 (see Appendix) we represent the developed author's tools of hedging the risks arising at the different stages of the innovation life cycle which will allow resolving the above mentioned problems.

1. The innovative company sells to venture fund the share of its own securities determined by the contract (stocks, bonds) at their par value.

This part of the transaction is carried out at the stage of an innovative product development as during this period of time the innovative company needs the greatest concentration of monetary resources.

2. Through the exchange the commodity American uncovered option "call" is purchased from the innovative company at the initial stage of the innovative company work. Thus, the innovative company, being at the stage of an innovative product development, insures itself against price falling of the product sold by it. And the innovative company gets an award from the buyer of an option.
3. The innovative company purchases the commodity European covered option "call" from the sellers of an option which are the suppliers of the current assets used in the production of the innovative product.
4. Buyers sign the deliverable forward contract with the innovative company at the start stage of production for the delivery of an innovative production in the future at the market price.
5. Implementation of the second phase of the relationship between the innovative company and the buyer of the commodity American uncovered option "call" realizing the start stage of a production and the beginning of sales of an innovative product at the price established in the first phase of the concluded bargain. It provides opportunity to insure the innovative company from the falling of the prices of its production if market conditions change.
6. Implementation of the second phase of relationship between the innovative company and the buyer of the commodity European uncovered option "call" realizing at the start stage of production and the beginning of an innovative product sales happens at the price established in the first phase of the concluded bargain. It provides the opportunity to insure the innovative company from the increase of the materials prices and accessories ones used at the

stage of production of innovative products regardless to the change of price.

7. The innovative company signs the estimated non-deliverable forward contract at the stage of active realization of innovative production at the price established at the current moment of time.
  8. The performance happens on the deliverable forward contract between the seller (the innovative company) and buyers at a stage of the active realization of innovative production at the market price. Thus, the innovative company insures itself against the possible falling of the realization volumes of the innovative production.
  9. According to the REPO terms of the transaction the innovative company redeems from the venture fund the share of its own securities sold to it at the in advance agreed cost.
- The innovative company carries out this process in at the stage of the innovative production active realization, i.e. at the time of the maximum receipt of financial resources from sale of the innovative production.
10. Performance of the contract between the venture fund and the innovative company happens during the possible falling of the price at the cost recorded at the stage of the innovative production active realization. Thus, the innovative company, having signed this contract, insures itself against the falling of the prices of its innovative production in the future.

Thus, the system of the consecutive hedging the risks arising at different stages of the life cycle innovations by financial instruments will allow to insure the company from possible financial and commodity risks at all development stages of the production and realization of an innovative product.

### **5. Mathematical model of calculation of the financial result received while using derivatives at an innovative product life cycle stages allowing to hedge possible risks of a venture company**

For calculation of the financial result which the innovative company can receive while using the derivatives at all stages of an innovative product life cycle we will take the developed system of the consecutive hedging the risks given above in the abstract as a basis by financial instruments.

In the system given above the main derivatives used when hedging risks were:

- ◆ REPO (transaction of the return REPO);
- ◆ commodity American non covered option call;
- ◆ estimated (non-deliverable) forward;
- ◆ commodity European covered option call;
- ◆ deliverable forward.

Further we will present the well-known formulas applied while calculating the financial result on each derivative separately.

1. Repo (transaction of the return REPO).

$$FR_1 = \frac{(C_2 - C_1)}{(t/365)}, \quad (1)$$

where:  $FR_1$  – financial result of the innovative company from application of REPO transaction;  $C_1$  – par value of securities of an innovative company at the time of its acquisition by a venture fund;  $C_2$  – cost of securities of the innovative company at the time of its sale by a venture fund;  $t$  – time period between sale and the return acquisition of securities by an innovative company; 365 – number of days in a year.

2. The commodity American non covered option call.

Let's remind that the American option is the option which can be realized until the end of the term of its action at any time. Respectively:

$$2.1. \text{ At } (ST > X), FR_2 = -(ST - X) + c \quad (2)$$

$$2.2. \text{ At } (ST \leq X), FR_2 = \text{with}, \quad (3)$$

where:  $ST$  – the price of the basic innovative asset by the time of the contract expiration;  $X$  – the execution price;  $c$  – option award.

3. Estimated (non-deliverable) forward.

Let's remind that the forward contract is the urgent contract obligatory for execution.

At first the forward price of the innovative product is calculated:

If "Z" is the definite cost, then:

$$F_1 = S_1(1 + r \frac{T}{365})Z. \quad (4)$$

If "z" is the percent (counting for a year) from the cost of innovative product paid for a storage and an insurance, then:

$$F_1 = S_1[1 + (r + z) \frac{T}{365}], \quad (5)$$

where:  $F_1$  – the forward price of innovative product (under the estimated (non-deliverable) forward contract);  $T$  – period of action of the forward contract;  $S_1$  – the spot price of innovative product (under the estimated (non-deliverable) forward contract);  $r$  – a rate without risk for  $T$  period;  $Z$  – expenses on storage and insurance of product during  $T$ ;  $z$  – the percent (counting for a year) from the cost of innovative product paid for storage and insurance.

Further the financial result determined by a difference between the spot and forward price of innovative product is calculated.

$$FR_3 = S_1 - F_1. \quad (6)$$

4. The commodity European covered option call.

Let's remind that the European option call is executed if the spot price of a basic asset ( $ST$ ) by the time of expiration of the contract is higher than the price of execution ( $X$ ) and is not executed if it is equal or lower than prices of execution. Respectively:

$$4.1. \text{ At } (ST > X), FR_4 = (ST - X) - c, \quad (7)$$

$$4.2. \text{ At } (ST \leq X), FR_4 = - \text{with} \quad (8)$$

5. Deliverable forward.

$$FR_5 = S_2 - F_2, \quad (9)$$

where:  $F_1$  – the forward price of innovative product (under the deliverable forward contract);  $S_1$  – the spot price of innovative product (under the deliverable forward contract).

After the calculation of financial results on each of the above presented derivatives is made it is possible to remove author's mathematical model for calculation of the financial result, from the consecutive application the above mentioned financial instruments at all stages of an innovative product life cycle.

At  $ST > X$ , the formula will have the following appearance:  $(-(ST - X) + c)(S_1 - F_1)((ST - X) - c)(S_2 - F_2)$ . (10)

At  $ST \leq X$ , the formula will have the following appearance:  $(S_1 - F_1)(S_2 - F_2)$  (11)

This mathematical model will allow to calculate the final financial result from application of the financial instruments of hedging by innovative company for all process of the life cycle innovations. Besides, this model will allow calculating the planned economic effect of the hedging instruments already at the initial stage of the development and starting of an innovative product.

The models can apply in the real world for increase significantly turnover of the assets by means of the free money growth which can be directed to the enhancement of the production and economic activity of the venture business. In its turn the process of the risks decrease from the negative consequences of derivatives which can arise for the venture funds, can be carried out by means of the insurance companies participation. In addition for the expansion of derivatives forms taken by the venture funds it is possible to connect the credit organizations and the investment funds.

### Conclusion

The problem of the innovative and investment “breakthrough” is very urgent for the economy of the Russian Federation. At the same time the realization of the effective investment policy is problematic without the close interrelation with the development of the securities market considering the fact that the stock market acts as the engine of the investments in the business where the financial risk is significantly great.

Despite of all adduced arguments in favor of the innovative and investment processes activization on the basis of stock market in Russia it is only at the formation stage and considerably lags behind the foreign one it is characterized by the lack of the considerable financial resources, big risks and backwardness of the derivative securities market.

The above mentioned arguments cause the lack of the domestic innovative financial instruments, weak and slow perception of the different countries experience.

These models allow us, firstly, increase significantly the current assets of the innovative company and to track the received financial result from the application of derivatives. Secondly, models allowing to hedge the possible risks of the venture company. Thirdly, models will allow calculating the planned economic effect of the hedging instruments already at the initial stage of the development and starting of an innovative product.

The main conclusions and offers received in course of the conducted research have as a purpose to make a certain contribution to the development of the innovative enterprises interaction problems of the venture funds by means of the derivatives.

### References

1. Drucker, P.F. (1985). *Innovation and Entrepreneurship*, New York: Harper & Row.
2. Folomev, A., V. Revazov (2001). *Innovative investment*, St. Petersburg, Science, 184 p.
3. Nechaev, A.S. (2012). Efficiency of investments attraction into organization of production processes at industrial enterprises, *Bulletin of Irkutsk State Technical University*, 3, pp. 237-241.
4. Nechayev, A.S., Antipina, O.V. (2013). Innovative and investment development in a control system of municipality, *Actual Problems of Economics*, 10, pp. 293-297.
5. Raevsky, S.V. (2006). *Investment activity in region*, Moscow, Publishing house, 158 p.
6. Porter, M.E. (1985). *Competitive Advantage*, New York, Free Press.
7. Shumpeter, J. (1961). *The Theory of Economic Development*, New York, Oxford University Press.
8. Yakovets, Y. (1999). *Cycles. Crises. Forecasts*, Moscow, Nauka, 448 p.

### Appendix

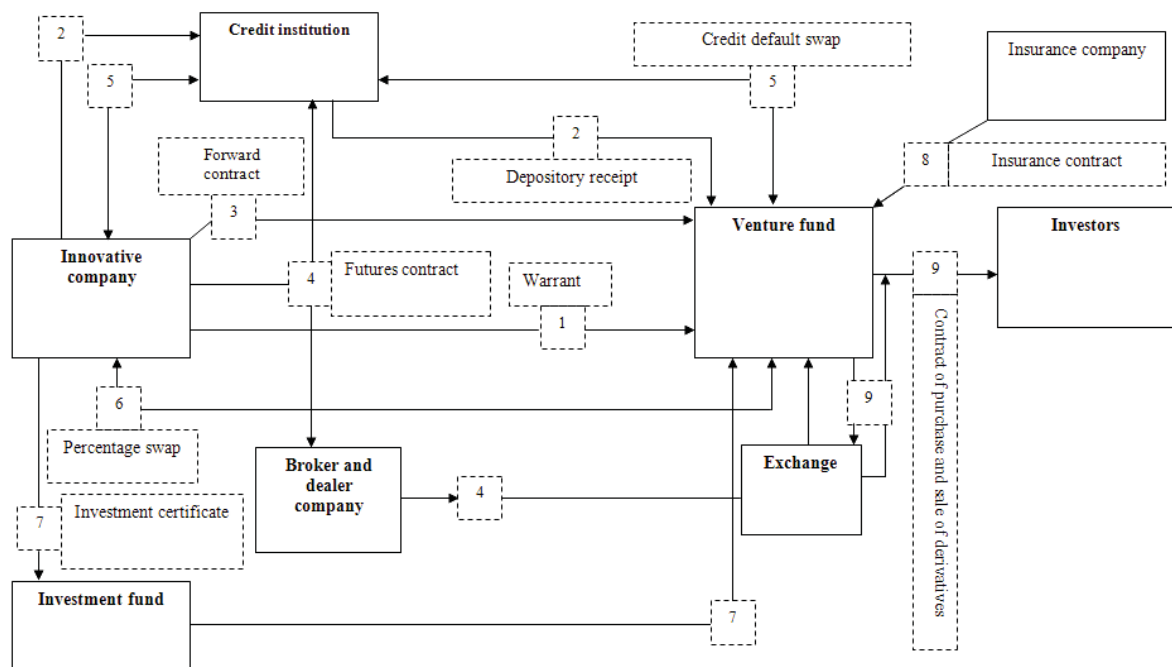

Fig. 1. Algorithm of interaction of the innovative company with venture fund by means of derivatives

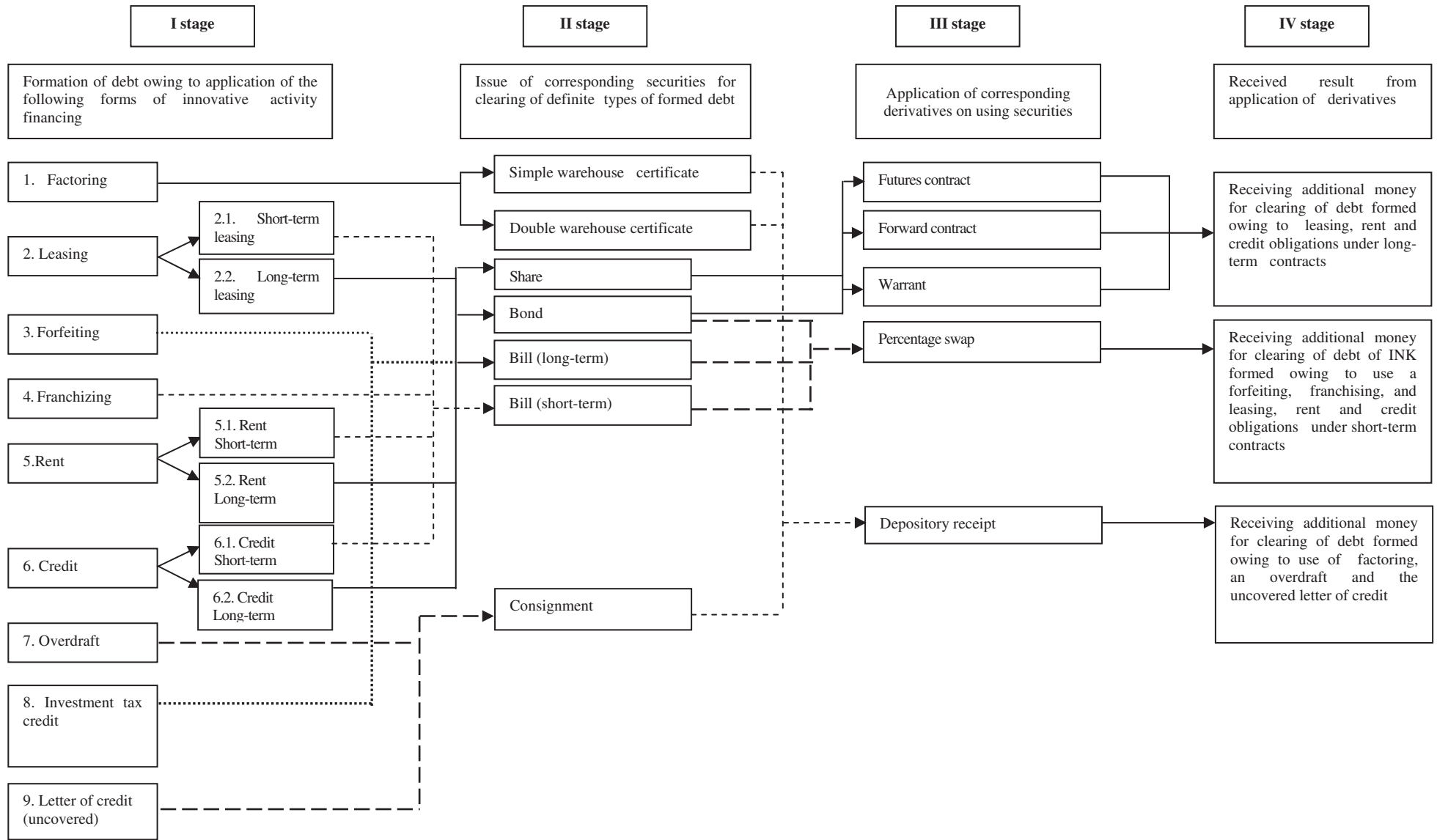

Fig. 2. Complex algorithm of the main forms of innovative activity financing reinvestment by derivatives



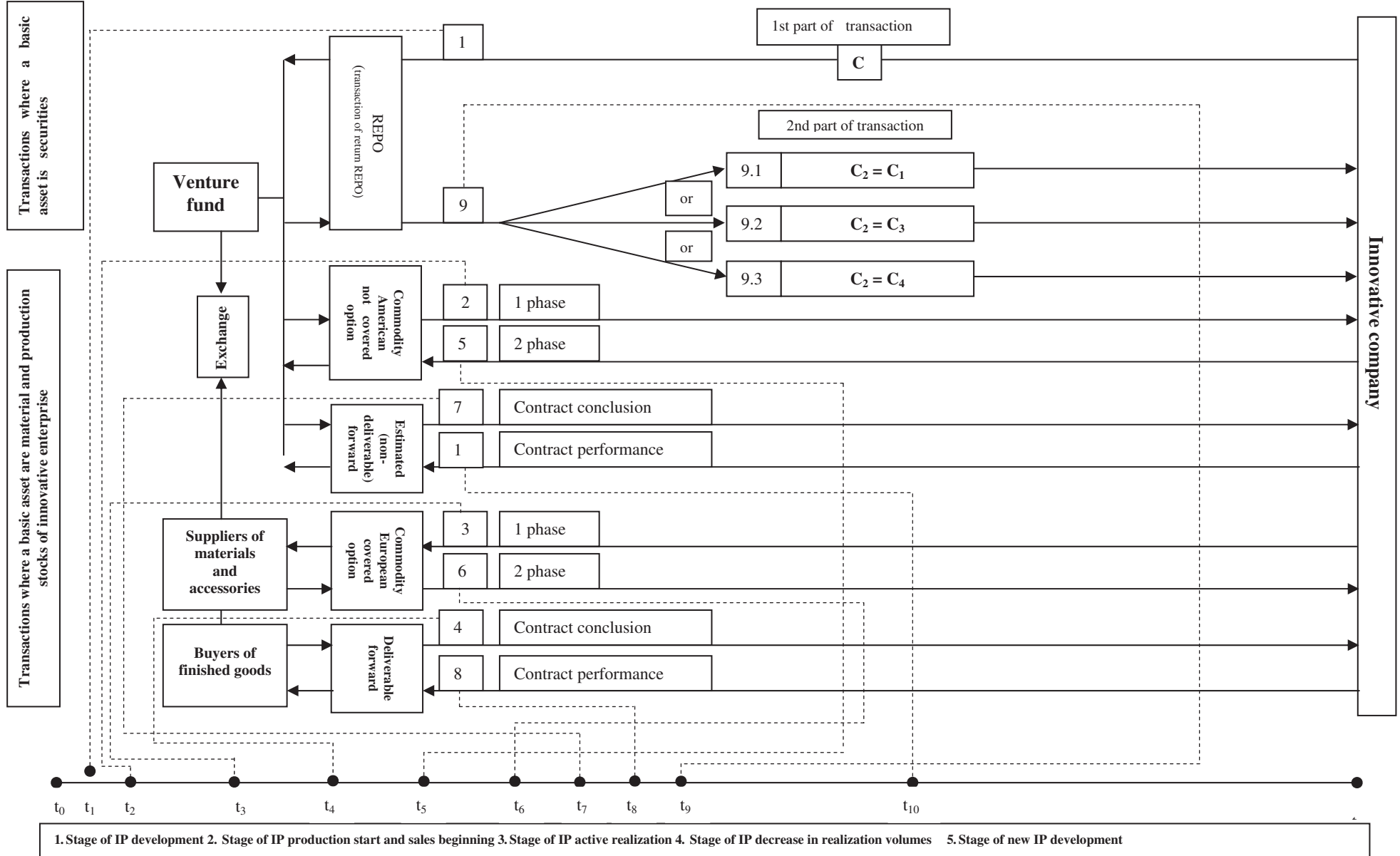

Fig. 3. System of consecutive hedging the risks arising at different stages of life cycle innovations by financial instrument