

Sofyan Rais (Indonesia), Robert V. Goedegebuure (UAE)

Corporate social performance and financial performance. The case of Indonesian firms in the manufacturing industry

Abstract

Literature suggests a relationship between corporate social performance (CSP) and organizational performance (as indicated by financial performance). Prior studies that use various proxies of CSP reveal mixed results. This paper examines stakeholder relations as a solid measure of CSP, and its impact on firm performance. Building on Clarkson (1995), the study points out that stakeholder relationships are meaningful measures of social performance. Survey data have been sampled gathered from 101 Indonesian manufacturing firms. Models have been tested using structural equation modeling. Our data indicate that CSP strongly and significantly affects both a firm's competitive position and its financial performance. The relationship between CSP and financial performance is not mediated by firm strategy. It is, however, mediated by the firm's strategic position in market place. We conclude that stakeholder-oriented CSP adds to the firm's competitive advantage. Firms that apply CSP strategies are thus able to do their businesses more effectively.

Keywords: stakeholder management, corporate social performance, strategy, strategic positional advantage, comparative advantage and financial performance.

JEL Classification: M1.

Introduction

Corporate social performance (CSP) embraces ethical and social realms of corporate life. Its practical value is still too vague to be measured for the sake of explaining normative social relationships of business (Reed, 2002). Many companies in fact are reluctant to reveal their social and environmental activities. A study conducted by Basmalah & Jermias (2005) in socially and environmentally sensitive areas such as mining, logging, and oil and gas in Indonesia found that the practice and motivation for social and environmentally reporting are associated with significant threats faced by the companies that might jeopardize their reputation, and even their ongoing survival. Thus, reporting tends to be negatively motivated, and biased in favor of the companies. The study of business/society relationships provides a new approach on how social performance contributes to the competitive advantage of firms.

Most research on CSP implicitly evaluates the firm's effectiveness in meeting the needs and expectations of stakeholders (Clarkson, 1995). CSP management in literature is associated with firm's capabilities (Hunt and Morgan, 1997), and strategic resources (Post et al., 2002). Positive effects of CSP on financial performance are found in Waddock and Grave (1997), Griffin and Mahon (1997), Preston and Bannon (1997). Positive effects on non-financial performance (cf. Turban et al., 1996) refer to the potential of CSP in enhancing reputation; minimizing conflicts with stakeholders; achieving cost savings; and increasing productivity.

Following Freeman's (1984) view of stakeholders as groups that affect or are affected by corporate objectives, our research focuses on the identification of

stakeholder relations as proxies of corporate social performance. Through their strategic orientation with respect to the stakeholders, firms respond to social and environmental needs. This study determines whether such orientation leads to an enhanced strategic position in the market place, and to improved social and financial performance.

The study contains several relevant points with respect to corporate stakeholder orientation in Indonesia. Firstly, social/stakeholder issues do strongly affect firm survival nowadays. Aswicahyono et al. (2005) argue that within the manufacturing industry, corporations should consider their primary stakeholders because a lack of maintaining human resource issues for example, causes the deteriorating sense of dedication in managers and workers; technological capabilities require modern capital equipment; shareholders and investors are those who encourage this access overtime; firms need to access suitable sources of consumers; communities play a critical role in supporting firm's operations in the long term. Secondly, the related issues of corporate social responsibility practices. Griffin (2000) emphasizes that firms that are being in the midst of restructuring process to improve their competitive positions (case of the most Indonesian manufacturing firms) require more responsiveness to internal and external expectations. The economic condition of Indonesia, government policies and business culture have encouraged more competitive challenges to the industry (Kompas, September 13th, 2006) following the increasing demand in social and environmental responsibilities. Kemp, already in 2001, raised the question whether at that stage of development corporate social responsibility is a relevant theme for Indonesia. She pointed out the historic and cultural factors that inhibited significant

changes in corporate social performance; flawed codes of conduct in the country; the country's vulnerability to environmental damage with particular reference to the mining and palm oil industries. In sum, the theme of corporate social responsibility was extremely relevant for Indonesia. However, reaping the maximum benefits from corporate social responsibility on both the macro-economic and the firm levels requires that all involved are fully aware of the mechanisms involved. We hope that by studying the relationship between CSP and organizational performance in the developing economy of Indonesia, the awareness of the potential and the pitfalls will pave the way to a positive and fruitful approach of CSR, in contrast to the defensive use of evident in Kemp's paper.

The rest of the article is organized as follows. In section 1 (after introductory section) we review literature on CSP, culminating into a research framework. In section 2 we develop research model and formulate the hypotheses for the study and present the methodology used to test them. Section 3 is data analysis and discussion of the findings. The last section is summary of the study and policy implications.

1. Literature review

1.1. Stakeholder orientation. Research on CSP has provided a variety of perspectives on the social roles and responsibilities of business (Wood and Jones, 1995). The outcomes show inconsistent results (Dentchev, 2004). Researchers usually use different theories and methodologies to model social performance (Wood, 1991). Before 1990, CSP research attempted either openly or implicitly to remain within the neoclassical paradigm. It stems from Friedman's (1970) contention that the social responsibility of business is to make profit. Like many neoclassical economists he separates business from society, and declares the concept of social responsibility as a fundamentally subversive doctrine. CSP incorporated externalities such as the corporate social matrix (Carroll, 1979; Wartick and Cochran, 1985). Freeman's (1984) stakeholder concept was widely adopted. Various studies have examined stakeholder relationships as proxies of CSP (e.g. in consumer studies Reilly & Hoffer (1983); Bromiley & Marcus (1989); and Bhattacharya & Sen (2003); in employee studies Turban & Greening (1996); in supplier studies Soehadi (2003) and Lynch (2000); in community and charity studies Keim (1978); Levy & Shatto (1980); Morris et al. (1990); in environmental studies Shane and Spicer (1983); Holman et al. (1985); and in corporate reputation studies Cochran and Wood (1984), Graves and Waddock (1994); Riordan et al. (1997)). An extended concept of CSP describes the contribution of business to

society. This so-called CSP-broad concept is associated with the ethical perspectives reflected by the principles of social responsibility and social responsiveness (Wood, 1991).

Our study however employs the CSP-narrow stakeholder framework as it is more appropriate for evaluating the practical value of integrating social issues within business objectives (Pierick et al., 2004). Several definitions of stakeholder such as Post et al.'s (2002) concept of wealth creating capacity, Donaldson & Preston's (1995) equidistant size and shape, and Clarkson's (1995) interrelated interests, show the practical value of the stakeholder framework to measuring CSP.

1.2. Strategic importance of CSP. The strategic importance of CSP is commonly evaluated through its influence on firm performance, or its interrelated function with other organizational attributes (Dentchev, 2004). Roman et al. (1999), in their exploration of studies of the corporate social and financial performance relationship, found a dominance of positive relationships; 33 studies using aggregate measure of CSP (like the Kinder, Linderburg and Dominique (KLD) or GRI indices) and profitability indices for financial performance show positive correlations, while 14 studies show no effects or were inconclusive, and only 5 studies show negative correlations. Studies using financial measures based on stock market indicators indicated diverse results (Tsoutsoura, 2004). Moore's (2001) study on a single industry with multiple social variables found that contemporaneous social and financial performance are negatively related, while prior period financial performance is positively related to subsequent social performance. Griffin and Mahon's (1997) report that out of 51 studies during 1970s to 1990s, 35 studies show positive correlations, 20 negative correlations and 9 show no effect. The business rationale of CSP management has been reported in Dentchev (2004). Using health, safety and environment variables as proxies of CSP, and business opportunities and threats as variables of competitiveness, he found that CSP leads to improved stakeholder relationships and enhanced corporate reputation. In sum, the large majority of studies support the view that CSP is strategically relevant to the firm.

1.3. Corporate Social Performance measures. The CSP construct has been measured by various frameworks such as Carroll's (1979) social responsibility; Preston and Post's interpenetrating system; Wood's (1991) social responsibility structure principle; Wartick and Cochran's (1985) issues management; Clarkson's (1995) stakeholder issues; and Davenport's (2000) corporate citizenship principles. In addition, many studies use the KLD or Fortune

Magazine data, on reputation indices and social dimensions respectively. Two basic approaches focus on processes or on outcomes (Preston, 1990a in Husted, 2000). Wood (1991) uses a process approach based on principles of corporate social responsibility (CSR1, hereafter), corporate social responsiveness (CSR2, hereafter) and social impact. Her definition of CSP indicates that stakeholders set norms for corporate behavior, experience the effects of corporate behavior and evaluate corporate behavior (Ruf et al., 2001). The corporation in return should anticipate the effect of policies and programs towards societal demands that affect its performance. Social performance is measured from the combination of all aspects of ethical perspectives. Models that look at CSP in terms of results are proposed by Clarkson (1991), Preston (1990), and Griffin & Mahon (1997). For measurement our study refers to the recommendation of Pierick et al. (2004) to use CSP-narrow because there is no adequate operationalization of CSP-broad in academic literature; CSR1 and CSR2 can only be inferred from observations of actual behavior.

1.4. Wood's model of CSP. Wood (1991) develops her model based on Wartick and Cochran's (1985) process based definition of CSP. She defines CSP as "a business configuration of principles of social responsibility, process of social responsiveness, and policies, programs, and observable outcomes as they relate to the firm's societal relationships". There are three parts in her operationalization. The first part, corporate social responsibility (CSR1), refers to the interpretation of CSP as being accountable for one's business activities (referred to as formulation of principles, or deontologist ethics). The second part, corporate social responsiveness (CSR2), refers to the interpretation of CSP as acting in accordance with societal demands (referred to as actual management behavior, or virtue and pragmatist ethics). The third part is the social impact (consequentialist ethics) that refers to the interpretation of CSP as acting without adverse consequences for natural and social environment (referred to as consequence of doing business). CSR1 is measured along four dimensions: economic, legal, ethical, and discretionary (Wartick and Cochran, 1985). CSR2 is measured as the Reactive-Defensive-Accommodative-Proactive (RDAP) standard proposed by Carroll (1979) indicating the intensity of the response. Social impact depicts the observable outcomes of firm social behavior against societal demands.

1.5. Clarkson's model of CSP. Clarkson's (1995) pragmatic model of CSP rests on a framework of stakeholder orientation (result oriented approach). It posits that the companies have responsibilities to those who have vested interests in the firm objectives and those who are directly affected by

the firm's actions (Freeman, 1984). CSP in his model is conceptualized as a single attribute that can only be understood when examined on a dimension-by-dimension basis such as employee relations, product quality concern against natural environment, and treatment of women and minorities or community relations.

In his review of researches conducted over more than 70 field studies regarding the corporate social performance from 1983-1993, Clarkson (1995) concluded that corporations manage relationships with stakeholder groups rather than society as a whole; stakeholder issues are treated as strategic issues while social issues are considered as non-core to business. Clarkson made an inventory of typical stakeholder issues based on field studies. The focus of his framework is on the management of stakeholder issues, rather than on the principles of CSR1 and CSR2. Managers interpret responsibility in the context of functional disciplines and of accountability for the results of their decisions. Obligations or responsibilities to customers, employees, or shareholders, and other important constituencies are defined along with corresponding accountabilities.

Research on CSP commonly focuses on a specific area or stakeholder group. Wood and Jones (1995) divided CSP measures into eleven areas (e.g., for community studies, employee studies, social justice studies, customer and consumer studies, corporate reputation studies). Our study, in contrast, uses the typical stakeholder issues model developed by Clarkson (1995). The items for each group of stakeholders involved, implicitly represents the principles of CSR1, CSR2 and social impact (SI). Although using concept of CSP-narrow the measurement therefore does embrace Wood's (1991) broad definition of corporate social performance, within one aggregate measure of CSP.

2. Research model and hypotheses

2.1. The research model. In our model several theories and prior studies have been integrated. The relational assets (RA) theory postulates that this type of assets creates competitive advantage that enhances the strategic position of a firm in the market place (Hunt & Morgan, 1997). Likewise, our model links resources to market position and financial performance. We use stakeholder theory in assuming that salient stakeholders set goals of a company based on their power, legitimacy and urgency (Mitchell et al., 1997). Primary stakeholder groups are those having more interdependency with the firm (Clarkson, 1995; Wood, 1995). Stakeholder studies indicate that the primary stakeholder groups – shareholder, employees, suppliers, customers, and communities – influence strategic decision making processes (Berman et al., 1999; Polonsky, 2002),

and are involved in wealth creation by the firm (Post et al., 2002). Lynch et al. (2000) link strategic resources with Porter's generic strategies and financial performance following the concept of strategic fit. Other studies investigate the relationship between corporate social performance and financial performance, either directly (Wood and Jones, 1995) or through firm strategy (Berman et al., 1999; Moore, 2001) reflecting an instrumental aspect of stakeholder typology (Donaldson & Preston, 1995).

Our model explores the impact of corporate social performance on firm performance following three alternative approaches.

- ◆ firstly, CSP is assumed to affect financial performance (monetary gain or MG, hereafter) directly;
- ◆ secondly, CSP is assumed to affect the firm's strategic positional advantage (VG, or value gain performance hereafter);
- ◆ thirdly, we assess the indirect effects of CSP on both MG and VG, using firm strategy as a mediating variable following the concept of strategic fit.

2.1.1. CSP – strategy-performance relationship model. Strategy is the process of linking the firm's vision, strategy, tactics, and implementation plan to gain a competitive advantage (Primo et al., 1991). It links the organization's

goals to environmental demands (Wheelen & Hunger, 2002). A high score on CSP reflects the firm's capability that drives the quality of strategic decisions.

Porter (1996) notes that a single strategy encompassing the near to medium term runs the risk of providing neither the basis for effectively running the existing business nor the basis for managing change. Our model uses his generic strategies of differentiation and cost leadership. The idea of duality in strategy is well recognized by strategists. Wheelen and Hunger (2002), for example, argue that research does not support the argument that a firm or unit must choose between either differentiation or lower cost in order to have success. Dual strategy is also explained by D'Aveni (1995), who contends that industries go through escalating stages of competition. Consequently companies must constantly work to improve their competitive advantage, by reducing costs and adding value to the products and services they provide.

2.1.2. Proposed research model. The research model is structured following the above approaches. We examine direct effects of CSP on MG; in addition, we examine the mediating effect of firm strategy into CSP-Performance relationships. The three approaches are summarized in Figure 1.

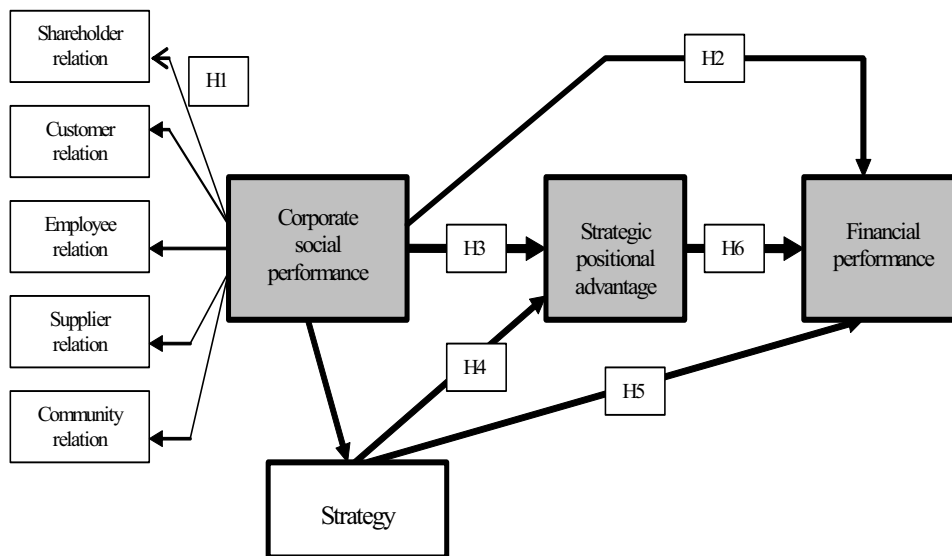

Fig. 1. Research model

2.2. Hypotheses. The overall research model is split into four sub-models:

- ◆ sub-model 1 analyzes primary stakeholder issues as manifest variables of the latent CSP construct;
- ◆ sub-model 2 analyzes the direct effect of corporate social performance on both MG and VG;
- ◆ sub-model 3 analyzes the mediating effects of strategy in the relationships between CSP and VG, and CSP and MG;

- ◆ sub-model 4 analyzes the mediating effect of VG in the relationship of CSP on MG.

2.2.1. CSP measure. CSP is measured as a single attribute of the firm. It represents an index of responses of the firm to stakeholders' issues in its efforts to achieve firm objective (Clarkson, 1995). CSP can positively or negatively affect the firm's financial performance, depending on the way it is managed (Post et al., 2002). Primary stakeholders

(shareholders, employees, customers, suppliers, and local communities) co-determine the success of the firm. It is hypothesized that:

H1: Primary stakeholders (shareholders, customers, suppliers, employees, and communities) individually and collectively comprise a reliable and valid instrument for measuring corporate social performance (CSP).

2.2.2. The direct effect of CSP on financial performance (MG). The strategic importance of CSP to contribute the competitiveness of the company has been studied by Moore (2001). His findings show a positive causal relationship between stakeholder relations and financial performance. Post et al. (2002) define relational assets as intangible resources through which value-creating capacity is created. Dwyer and Singh (1998) stress the value of inter-firm relationships in supply chains. Donaldson and Dunfee (1994) argue that implicit normative agreements (or micro-social contracts) reduce opportunism among stakeholders, thus enhancing a firm's economic performance. It is hypothesized that:

H2: CSP significantly and positively directly affects the firm's financial performance.

2.2.3. The direct effect of CSP on firm positional advantage. RA theory argues that the competitive advantage of the firm derived from its relational asset, will contribute to its strategic position (value-gain) in the market place (Hunt & Morgan, 1997). It is hypothesized that:

H3: CSP directly influences its positional advantage or value-gain performance.

2.2.4. The mediating effect of strategy on CSP-firm performance relationship. The influence of CSP on performance can be measured also via strategy as a compounding variable as an alternative to earlier hypotheses (direct effect of CSP). The mixed outcomes of the direct effect of CSP on MG in previous studies led Burke and Logsdon (1996) to raise the question under what conditions a firm can jointly serve its own business interests and the interests of its stakeholders. Ullmann (1985, in Moore (2001)) proposes the inclusion of strategy in the relationship to explain the nature of the causal effect. Firms pursuing a strategy with CSP as its strategic capability are assumed to outperform firms with a similar strategy but without that capability. In other words, CSP is not a separate, independent organizational attribute, but it hinges on the business strategy. Husted (2000), in testing the conformity between

stakeholder issues and the corresponding strategies, found that a match between the two positively affects the firm's performance. It is hypothesized that:

H4: The effect of CSP on the firm's positional advantage is mediated by strategy; CSP will drive strategy which in turn affects the strategic positional advantage.

H5: The effect of CSP on the firm's financial performance is mediated by strategy; CSP will drive strategy which in turn affects financial performance or monetary gain performance.

2.2.5. The mediating effect of strategic positional advantage. Hunt and Morgan (1995; 1997) argue that competitive advantages dictate a strong market position, and lead to superior quality, efficiency, innovation, and ultimately performance (Hunt & Morgan, 1995). It is hypothesized that:

H6: The effect of CSP on the firm's financial performance is mediated by its strategic positional advantage; CSP will drive its strategic positional advantage which in turn affects the firm's financial performance.

2.3. Data. The main constraint in CSP research is the availability of CSP data. In Indonesia, no report regarding CSP in any industry was available. The study, therefore, designed the methodology to collect relevant data, in line with the CSP-narrow approach and the research model set out in the above. Field research was executed in 2005.

2.3.1. Variables. The theoretical model depicts the manifest variables used to measure latent variables (CSP, strategy (STR), positional advantage (VG), and firm performance (MG)). The measurement of CSP is derived from primary stakeholder issues as defined by Clarkson's (1995), Davenport's (2000), Moore's (2001), Dillenburg et al. (2003), and Backhaus et al. (2002). For the strategy construct observable items are derived from Dess and Davis' interpretation of Porter's generic strategies (Lynch et al., 2000). For performance constructs (VG and MG), the study has used traditional accounting based financial and non-financial indicators. For the operationalization of the variables we refer to the questionnaire (Appendix A).

2.3.2. CSP construct. The stakeholder framework for measuring CSP offers a realistic approach to translating the principles of social responsibility and social responsiveness in outcome based measures. Table 1 elaborates the instrument used to measure CSP.

Table 1. Operationalization of CSP

CSP	Dimensions *	Items **
Employee relations	1.1. Equal opportunity policy. 1.2. Health insurance policy. 1.3. Career evaluation and planning. 1.4. Training and development. 1.5. Employee protection & rights.	10. Observable indicators (EMR01 to EMR10).
Customer relations	2.1. Customer care. 2.2. Customer rights & protection.	5 Observable indicators (CSR1 to CSR5).
Shareholder relations	3.1. Shareholder rights. 3.2. Governance practices.	5 Observable indicators (SHR1 to SHR5).
Supplier relations	4.1. Supplier rights & protection. 4.2. Standard of supplied goods.	5 Observable indicators (SPR1 to SPR5).
Community relations	5.1. Community protection. 5.2. Community development.	5 Observable indicators (CMR1 to CMR5).

Note: * Source: Adopted and modified from Clarkson (1995), and Moore (2000); ** Details in Appendix A.

2.3.3. *Strategic positional advantage (VG)*. Hunt (1999) argues that firms occupy a market position and possess a competitive advantage if they engage in proactive innovation; they continually reinvest in the resources that produce the competitive advantage; and rivals' efforts to acquire the firm or innovate reactively fail. Indications of these achievements are strong market share and continuous delivery of product quality. The measurement of positional advantages is based on the so-called value-gain performance that reflects achievement in the market (Ciptono, 2005). VG is measured by 4 observable indicators (VG1 to VG4; see Appendix A).

2.3.4. *Financial performance construct (MG)*. Using accounting based financial performance, this study allows more comprehensive tests (Ciptono, 2005). MG is measured by 4 observable items (MG1 to MG4; see Appendix A).

2.3.5. *Strategy construct*. Porter' generic strategies best match the criteria of the manufacturing industry and its competition environment (Kumar et al., 2000). The strategy focuses on factors external to the firm such as market conditions and competition (Lynch, 2000), that drive firms to predominantly compete on price, differentiation, or both. Success in controlling expenses is an indicator of cost leadership, while success in delivering innovative products and serving targeted customers is an indicator of differentiation. The purpose of using generic strategies in this study is not to determine whether low-cost strategy is better or worse than a differentiation strategy in influencing CSP link to performance, but rather the effect of any dominantly strategy used in enhancing the effect of CSP on financial performance. Table 2 describes the measurement of strategy.

Table 2. Operationalization of strategy

Strategy	Dimensions *	Variable Items **
Cost leadership	1.1. Overall efficiency policy.	4 Observable items (CL1 to CL4).
	1.2. Low-cost product development.	
Differentiation	2.1. New product and/or service differentiation.	4 Observable items (DF1 to DF4).
	2.2. Quality Differentiation	

Note: * Source: Adopted from Lynch et al. (2000); ** Details in Appendix A.

3. Data analysis

3.1. *Sample*. To test the hypotheses, data on the relationship between firms and their primary stakeholders, and on firm strategy and performance have been collected from a sample of manufacturing firms in the district of Jakarta, Indonesia. The sample was drawn from the database of Central Bureau of Statistics Indonesia, and cross-checked with the Indonesian Yellow Pages Industrial Guide 2005. General data on the sampled firms (product category, stakeholder information, strategy and performance) were obtained from primary and secondary sources. Data on stakeholder groups were based on qualified information received at the previous stage. A total of 570 medium sized enterprises (employing between 100 and 1200 workers) in the manufacturing industry indicated their willingness to participate in the survey. A total of 109 companies finally returned complete questionnaire packages, out of which 101 firms were included for data analysis showing a response rate of 17.7 percent. Data were generated through questionnaires using seven-point Likert scales for all items and constructs (see Appendix). The final net sample consists of 101 firms; 42 firms are located in Jakarta, and 59 firms from three areas surrounding the Jakarta. For each firm, questionnaires were distributed to, on average, 1.4 sharehold-

ers; 1.7 customers; 1.7 suppliers; 5.1 employees, and 4.7 community members (see Table 3 for an overview). Although the response rate, on firm level, is low (17.7%), the absolute number of cases (101) is sufficient for applying structural equation modeling using LISREL (Hair et al., 1998). Table 3 gives an overview.

Table 3. General information of sample firms

Description	Location		
	Jakarta	Surrounding	Total
Number of respondents *			
a. Shareholder group	52	93	145
b. Customer group	64	105	169
c. Supplier group	64	104	168
d. Employee group	210	302	512
e. Community group	184	293	477
Total	574	897	1.471
Total **	42	59	101

Note: * Number of persons; ** Number of firms.

3.2. Scale construction. Our model consists of eight latent variables. We use factor analysis to construct the latent variables. Item reliability (Cronbach's α), validity (factor loading-L), construct reliability and variance extracted have been used in support.

3.2.1. Reliability and validity tests. Reliability and validity are two concepts used to test the quality of data before examining the structural model. For reliability, we use item reliability and construct reliability. Validity is tested using discriminant validity. Item reliability is measured by Cronbach's α for each scale; coefficients vary between 0.616 and 0.967. These scores are considered "good" as they exceed the threshold value of 0.5 (Sekaran, 1992; Hair et al., 1998).

Table 5. Goodness-of-fit measures for CFA: initial and final results

Goodness-of-fit measures	χ^2	df	P	RMSEA	GFI	AGFI	RMR	Remark
Constructs								
Before items removed:								
SHR	10.89	5	0.0536	0.109	0.96	0.87	0.047	Remove SHR1 to improve model
CSR	5.38	5	0.3709	0.028	0.98	0.94	0.024	accepted
EMR	33.76	32	0.3826	0.023	0.94	0.89	0.041	accepted
SPR	3.37	3	0.3377	0.035	0.99	0.93	0.023	accepted
CMR	2.02	2	0.3648	0.009	0.99	0.94	0.020	accepted
STR	15.17	8	0.0600	0.100	0.96	0.85	0.064	Remove DF 3 to improve model
VG	6.52	3	0.0889	0.108	0.96	0.88	0.021	accepted
MG	3.83	2	0.1473	0.098	0.98	0.91	0.022	accepted
After items removed:								
SHR	1.06	2	0.5880	0.000	0.99	0.97	0.016	accepted
STR	7.50	7	0.3785	0.027	0.98	0.92	0.034	accepted

3.3. Assessment of overall model fit. The assessment of the model embraces various goodness-of-fit criteria. Wijanto (2000) suggests that the minimum cases to ensure appropriate use of maximum likeli-

Table 4. Item reliability test result (N = 101)

Construct name	Construct code	No. of items	Cronbach's alpha
Shareholder relations	SHR	5	0.719
Supplier relations	SPR	5	0.832
Employee relations	EMR	10	0.967
Customer relations	CSR	5	0.845
Community relations	CMR	5	0.927
Strategic positional advantage	VG	4	0.839
Financial performance	VG	4	0.886
Strategy	STR	8	0.616

Validity is the extent to which the indicators accurately measure what they are supposed to measure (Hair et al., 2000). As a measure of validity we apply the confirmatory factor analysis (CFA) through examining the estimated loading and the statistical significance of the scales in each construct. To improve the model fit we remove the standard loadings below 0.7 which corresponds to a valid measure of 0.5 (the square of indicator's standardized loading). As a result SHR1 (CSP construct), and DF3 (strategy construct) have been removed. Table 5 depicts the improvement of goodness-of-fit measures of the revised constructs after removing those two item(s) as the smallest loading coefficients.

A further step after finding the model fit for all constructs, Cronbach's alpha test is re-performed to ensure that the reliability of constructs with the remaining items is acceptable. Test results show that after the items are removed, Cronbach's α of new SHR and strategy constructs drop to 0.592 and 0.656 respectively. However, they are still acceptable.

hood estimation (MLE) should be approximately four to five times the observable items in a complex model. In the initial model depicted in Figure 1 we have 50 observed items implying that the sample

size should be larger than 200. To match our sample size a simplified model is developed using the method of latent variable score (Joreskog, K.G., 2000). In the simplified model, the total number of observable variables is reduced to 24; our N = 101 sample is adequate for model evaluation.

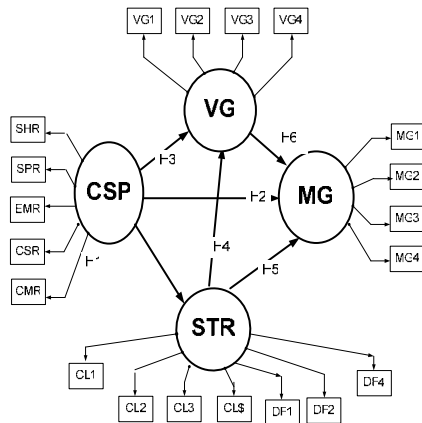

Fig. 2. Simplified model

3.3.1. *Evaluating goodness-of-fit criteria.* In confirmatory factor analysis (CFA), the overall model fit portrays the degree to which the specified indicators represent the hypothesized constructs. In evaluation of the results, this study uses the absolute fit measure represented by three indicators, which are likelihood-ratio chi-square (χ^2), the goodness of fit index (GFI), and the root mean square residual (RMSR), or root mean square error of approximation (RMSEA). Evaluation of relationships is examined through the indicative coefficient of determination (R^2), while the t-value at 95% confidence level is used to evaluate the level of significance of the relationship. Table 6 portrays the results.

Table 6. Results of goodness-of-fit measures of the hypothesized model

Goodness of fit measures	Value	Acceptable parameter level *	Status
Chi-square (χ^2) of estimated model	19.09		
Degree of freedom	15		
Significance level	0.21		
Goodness-of-fit index (GFI)	0.95	Close to 1 is better	Good fit
Root mean square residual (RMR)	0.05	Close to 0 is better	Accepted
Root mean square error of approximation (RMSEA)	0.05	<0.08	Accepted
Adjusted goodness-of-fit index (AGFI)	0.89	>0.80	Good fit
Normed fit index (NFI)	0.95	>0.90	Accepted
Comparative Fit Index (CFI)	0.99	>0.90	Accepted
Incremental Fit Index (IFI)	0.99	>0.90	Accepted
Relative Fit Index (RFI)	0.91	>0.90	Good fit

Note: * Hair et al. (1998, p. 635).

3.4. Hypotheses testing.

H1: Relationships with primary stakeholders comprise a reliable and valid instrument for measuring corporate social performance (CSP).

Results of structural model (see Fig. 3) show a good model fit, indicating that the theoretical model is in accordance with the data. Complementary assessments of item and construct reliability give further support to CSP as a latent variable measured by manifest stakeholder relationships. The five stakeholder relationships (shareholder, supplier, employee, customer and local community) have proven reliable measures. Therefore, the hypothesis (H1) stating that the five stakeholder relationships are reliable measures of corporate social performance is accepted.

3.4.1. *Shareholder relations (SHR).* Shareholder relation variables focus on measuring such indicators as return on investment and compliance with corporate governance policy, quite similar to the TSI benchmarks that indicate that owners and investors deserve a fair and competitive return, transparency of company operations and finances, and appropriate voice in corporate governance (Dillenburg et al., 2003). The path coefficient for SHR (0.46) is lower than the path coefficients for the other constructs, suggesting that shareholder relations are a weaker indicator of social performance than the other constructs.

3.4.2. *Supplier relations (SPR).* In line with Clarkson (1995), the data suggest that supplier relations are an important indicator of social performance, as the path coefficient is 0.68. As in Wood (1999), the principles of social responsibility relate to economical standards (supplier satisfaction); moral and ethical standards (meeting supplier rights; product safety); and discretionary standards like supplier protection. Dillenburg et al. (2003) added that suppliers or supply chain associates deserve mutual respect and long-term stability in return to value, quality, competitiveness, reliability, and employment practices that respect human dignity which are all implicitly incorporated in the items.

3.4.3. *Employee relations (EMR).* Employees hold power over the success of the firm, for instance through labor unions in some industries (cf. Conti, 2002). As an indicator of CSP construct, the path coefficient of EMR is 0.64. Apart from the typical employee issues (treated with dignity; safety; fair compensation) that directly affect labor productivity, employee moral can be assumed to serve other stakeholders (customers, communities, other social groups) indirectly as explained in Wood's (1999) CSP model.

3.4.4. *Customer relations (CSR).* The model shows a path coefficient of 0.67, indicating that customer relations are among the most important indicators of CSP. The findings corroborate the marketing literature (cf. Hunt and Morgan, 1997a, 1997b; Srivastava et al., 1998; Hunt, 1999).

3.4.5. *Community relations (CMR)*. As evidenced by the high path coefficient (0.81), CMR is the most typical indicator of CSP. From five variable items used to measure CSP, items of ‘providing support for social life of community’ and ‘support to protect environmental damage’ are the most influential issues of CMR indicators. Davenport (2000) argues that there are several commonalities to explain why CMR is much used as a proxy CSP measure: (1) community in general is constituent who perceives most effect of firms’ activities directly or indirectly; (2) products of certain manufacturing industries such as “environmentally safe” easily generate receptive image to the community resulting in good publicity; (3) community as a social entity stays outside of business activities, but perceives the negative impact of the results that embrace the environmental problems.

H2 and 3: CSP directly affects the firm’s financial and value-gain performance.

For testing Hypotheses 2 and 3, we use coefficient values of all relationships in the structural model as depicted in Table 7.

Table 7. SEM results of the hypothesized model (N = 101)

Structural relation (Causal path)	Coefficient value	T-value	Std. error
CSP → STR	0.03	0.25	0.15
CSP → VG	0.60	5.76 **	0.08
CSP → MG	0.13	1.90 *	0.05
STR → VG	0.10	1.15	0.05
STR → MG	0.01	0.19	0.04
VG → MG	0.85	13.91 **	0.06

Note: * One-tailed t-test $p \leq 0.05$; ** $p \leq 0.01$.

The results indicate that CSP significantly affects VG and MG, at the confidence level. Therefore H2 and H3 are supported. Stakeholder orientation in CSP management ensures that firms uphold their strategic positions in the market place (cf. Hunt, 1995). Good social performance does not lead to poor financial performance (cf. Roman et al., 1999; Jawahar & McLoughlin, 2001). The findings support the notion of corporate social performance as a

business rationale by strengthening corporate competitiveness.

H4, 5 and 6: The effect of CSP on the firm’s positional advantage is mediated by strategy (H4); the effect of CSP on the firm’s financial performance is mediated by strategy (H5); the effect of CSP on the firm’s financial performance is mediated by its strategic positional advantage (H6).

In indirect effects, the effect of an independent variable on a dependent variable occurs indirectly through a third variable. The indirect effect is also called a mediation effect (Sekaran, 1992), and the third variable is called the mediator variable. An indirect effect occurs if the independent variable significantly affects the mediator variable, and the mediator variable significantly affects the dependent variable. The amount of indirect effect is obtained by multiplying the path coefficients (Baron & Kenny, 1986). The indirect coefficients of CSP on MG through STR, and CSP on VG through STR, and CSP on MG through VG are calculated in Table 8. The statistical assessment provides evidence that the CSP-MG relationship is mediated strongly and significantly by market strategic position (H6). This finding is in line with the argument of Hunt and Morgan (1997) with regard to the effect of comparative advantage (CSP) on competitive advantage (VG), leading to superior financial performance. The study supports the argument of Post et al. (2002) who postulate that the achievement of financial performance derives from strategic relational assets.

The outcomes of indirect calculations reveal that the relationship between CSP and financial performance is strongly and significantly mediated by the value gain performance (H6). The CSP-VG relationship is positively and significantly mediated by strategy, though the size of the effect as indicated by the coefficient of 0.06 is small (H4). The results show no significant mediating effect of strategy on the CSP-MG relationship. Therefore, H5 is not supported, while H4 and H6 are. The final model is displayed in Figure 3.

Table 8. The direct and indirect effects of exogenous variable, mediating variables on firm performance

Dependent variable	Independent variable	Direct effect	T-value	Indirect effect via STR		Indirect effect via VG	
					t-value		t-value
MG	CSP	0.13	1.90*	0.001	0.21	0.50	7.04 ***
VG	CSP	0.60	5.76 ***	0.06	4.62 ***	N/A	N/A

Note: * $p \leq 0.1$; ** $p \leq 0.05$; *** $p \leq 0.01$.

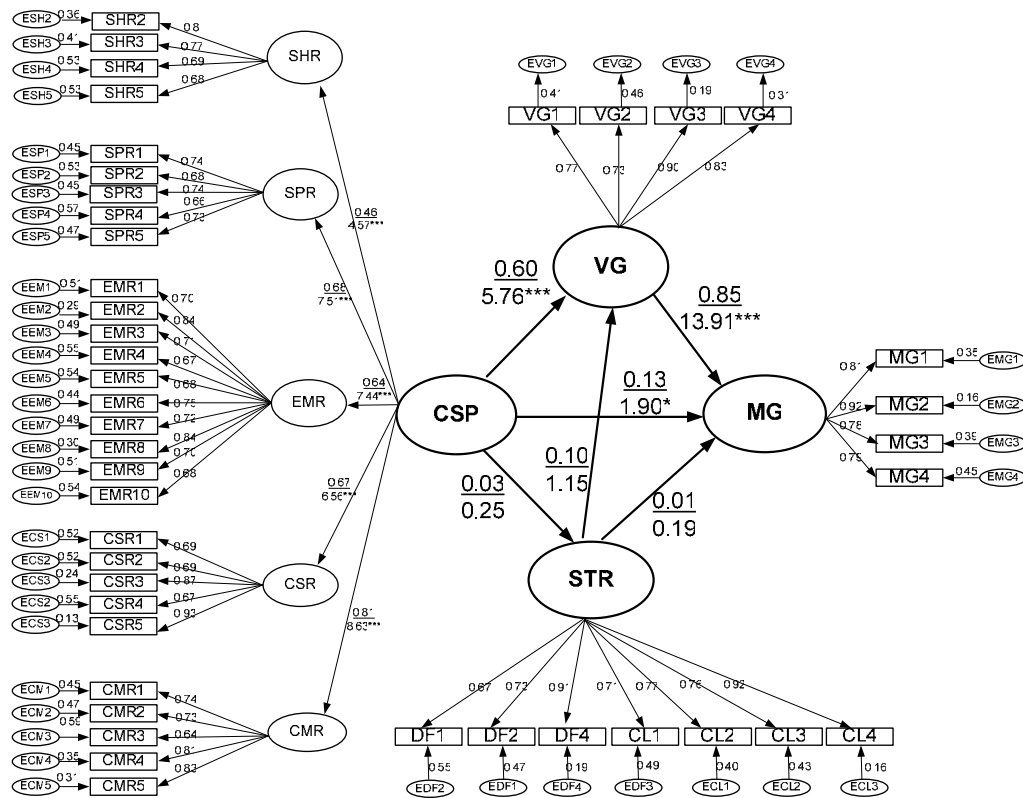

Legend:

CSP: Corporate Social Performance
 STR: Strategy
 VG: Strategic Positional Advantage (Value Gain)
 MG: Financial Performance (Monetary Gain)
 SHR: Shareholder Relation
 SPR: Supplier Relation
 EMR: Employee Relation
 CSR: Customer Relation
 CMR: Community Relation

*** : significant $\alpha/2 = 1.0\%$;
 ** : significant $\alpha/2 = 5.0\%$;
 * : significant $\alpha/2 = 10.0\%$

Fig. 3. Final model

Summary, conclusions and policy implications

This study addresses what is becoming crucial question in socio-economic model of business: whether there is a relationship between the achievement of corporate social performance and business performance. From the analyses we have, it can be inferred that corporate social performance is not left unrewarded. It leads to a better firm performance in terms of revenue and profit growths. CSP management drives firm market positional advantage, indicated by the increased reputation, product image, and other non-financial indicators. According to Orlitzky (2000), this is due to outcomes based reputation effects, rather than process based social responsibility, or managerial values and attitudes to social response. That is, even though investors tend to ignore social audits, social responsibility and responsiveness and even though disclosures are in fact negatively correlated to accounting returns,

CSP management through a stakeholder oriented approach evidently has the potential to enhance profitability. CSP therefore is to be viewed as complex and nuanced (cf. Dentchev, 2004).

Direct effects. Results of our final model (Fig. 3) show that all five stakeholder relation variables display a strong, significant correlation as manifest variables of CSP. Therefore, the study confirms that primary stakeholder relationships constitute a solid measure of CSP. The statistical analyses show that CSP positively and significantly influences both firm value-gain performance (VG) and monetary-gain performance (MG). These findings uphold the propositions noted in the concepts of resource advantage theory (Hunt, 1999) and resource based view (Barney, 1990). Both postulate that relational assets are a strategic resource instrumental in generating comparative and competitive advantages. The results emphasize the importance of CSP manage-

ment in achieving both positional advantages in the market place such as increased market share, market penetration, sales volume, and productivity rate, and financial performance as indicated by revenue and profit growth. Stakeholder oriented CSP management ensures that the firm maintains its strategic position in a market place characterized by heterogeneous demands, imperfect and costly consumer information, and a state of disequilibrium (cf. Hunt, 1997). The results support the idea that social performance enhances financial performance (Roman et al., 1999). The study also supports the notion of corporate social performance as a business rationale in enhancing corporate image and reputation (value gain performance).

Indirect effects. Our model indicates that business strategy is not a mediating factor in the CSP-performance relationships. The indirect effects of CSP on MG and VG via strategy are insignificant (MG) and significant with small coefficient (VG) respectively. These results deviate from the resource based view that postulates that a fit between strategy and resource will lead to better performance. Strategic management concept denotes that strategic fit between resource and strategy can be mapped into several perspectives such as matching, co-variation, profile deviation, mediation, moderation and adaption (Venkatraman & Camillius, 1984). We conclude that CSP and the strategy variables used in the study seem to be separate antecedents to firm performance, rejecting strategy as a mediating variable.

Statistical assessment of the structural model in Figure 3 provides evidence that CSP-MG relationship is mediated strongly and significantly by strategic position (VG). This finding is in line with the argument of Hunt and Morgan (1997) arguing that the comparative advantage (CSP) significantly af-

fects the firm's competitive advantage (VG), and this in turn enhances financial performance. This is in line with Post et al. (2002) who argue that the achievement of financial performance derives from maintaining long-term strategic relational asset with influenced constituents. The results of this study, that is, suggest that there is a business rationale to CSP management.

Policy implications. In order to advance the conceptualization and operationalization of CSP from a stakeholder orientation perspective, and its potential effect on financial performance, this study marks several practical implications:

1. CSP is derived from variables of stakeholder issues management. Therefore, it is essential that firms focus on social issues generated by stakeholders, organizational actions in responding the issue, and public effects of the issue.
2. The increasing social influence of media and other intermediaries in organizational networks (such as firm-consumer, firm-investor, and firm-community relations) can be used as strategic lever, thus enhancing CSP management.
3. CSP has the potential to reach strategic market position. A firm's relational assets together with other resources such as financial, human, physical, legal, informational become strategic resources if synergized effectively and efficiently toward the environment (Hunt, 1999). Although there is a no indication of strategic fit with generic strategies in this study, managing strategic relationships in line with other resources and strategies (e.g., human and HR strategies) is recommended. Wheelen and Hunger (1998) argue that failure to optimize the firm's strategic resources will impair the competitive position of the firm.

References

1. Aswicahyono, H., R. Atje and T.K. Wie (2005). Indonesia's Industrial Competitiveness: A Study of the Garments, Auto Parts and Electronic Component Industries. The World Bank, Development Economics Research Group, Working Paper Series.
2. Backhause, K.B., B.A. Stone and K. Heiner (2002). Exploring the Relationship between Corporate Social Performance and Employer Attractiveness, *Business & Society*, 41, No. 3, pp. 292-318.
3. Baron R.M. and D.A. Kenny (1986). The moderator-Mediator Variable Distinction in Social Psychological Research: Conceptual, Strategic, and Statistical Consideration, *Journal of Personality and Social Psychology*, 51, No.6, pp. 1173-1182.
4. Basamalah, A.S. and J. Jermias (2005). Social and Environmental Reporting and Auditing in Indonesia: Maintaining Organizational Legitimacy? *Gajah Mada International Journal of Business*, 7, No. 1, 109-127.
5. Barney, J. (1990). Firm Resource and Sustained Competitive Advantage, *Journal of Management*, 17, No. 1, pp. 99-120.
6. Berman, S.L., A.C. Wicks, S. Kotha, and T.M. Jones (1999). Does Stakeholder Orientation Matter? The Relationship between Stakeholder Management Models and Firm Financial Performance. *The Academy of Management Journal* 42, no. 5 (1999), 488-506.
7. Bhattacharya, C.B., and S. Sen (2003). Consumer-Company Identification: A Framework for Understanding Consumers' Relationships with Companies, *Journal of Marketing*, Vol. 67, April, pp. 76-88.
8. Burke, L. and J. Logsdon (1996). How Corporate Social Responsibility Pays Off, *Long Range Planning*, 29, No. 4, pp. 495-502.
9. Carroll, A.B. (1979). A Three-Dimensional Conceptual Model of Corporate Performance, *Academy of Management Review* 4, No. 4, pp. 497-505.

10. Ciptono, W.S. (2005). Exploring the linkages between Deming's Principle, World-Class Company, Operational Excellence, and Company Performance in an Oil and Gas Industry Setting, *Gajah Mada International Journal of Business*, 7, No.2, pp. 205-239.
11. Clarkson, M.B.A. (1991). Defining, Evaluating, and Managing Corporate Social Performance: The Stakeholder Management Model. In: L.E. Preston (Ed), *Research in Corporate Social Performance and Policy*, Vol. 2 (91), 331-358.
12. Clarkson, M.B.A. (1995). A Stakeholder Framework for Analyzing and Evaluating Corporate Social Performance. *Academy of Management Review*, 20, No. 1, pp. 92-117.
13. D'Aveni, R.A. and R. Gunther (1995). *Hyper-Competitive Rivalries: Competing in Highly Dynamic Environments*. New York: The Free Press.
14. Davenport, K. (2000). Corporate Citizenship: A Stakeholder Approach for Defining Corporate Social Performance and Identifying Measures for Assessing It. *Business & Society*, 39, No. 2, pp. 210-219.
15. Dentchev, N.A. (2004a). Corporate Social Performance as a Business Strategy, *Journal of Business Ethics*, 55, No. 4, pp. 395-410.
16. Dentchev, N.A. (2004b). *To What Extent is Business and Society Literature Idealistic*, Faculty of Economics and Business Administration. Gent, Belgium: Gent University: Working paper 2004a.
17. Dentchev, N.A. (2005). *Corporate Social Performance: Business Rationale, Competitiveness Threats and Management Challenges*. Gent, Belgium: Gent University.
18. Dillenburg, S., T. Greene and H. Erekson (2003). Approaching Socially Responsible Investment with a Comprehensive Ratings Scheme: Total Social Impact. *Journal of Business Ethics*, 43, pp. 167-177.
19. Donaldson, T., and L.E. Preston (1995). Stakeholder Theory of the Corporation: Concepts, Evidence, and Implications, *Academy of Management Review*, 20, No. 1, pp. 65-91.
20. Donaldson, T., L.E. Preston, L.E. and T.W. Dunfee (1994). Toward a United conception of Business Ethics: Integrative Social Contract Theory, *Academy of Management Review*, 19, No. 2, pp. 252-284.
21. Dwyer, J.H. and H. Singh (1998). The Relational View: Cooperative Strategy and Source of Interorganizational Competitive Advantage. *Academy of Management Review*, 23, No. 4, pp. 660-679.
22. Freeman, R.E. (1984). *Strategic Management: A Stakeholder Approach*. Boston: Pitman.
23. Freeman, R.E. (1999). Divergent Stakeholder Theory. *Academy of Management Review*, 24, No. 2, pp. 233-236.
24. Friedman M. (1970). The Social Responsibility of Business is to Increase Profit, *The New York Time Magazine*, September 13, pp. 122-126.
25. Grave, S.B. and S.A. Waddock (2000). Beyond Built to Last: Stakeholder Relations in Built-to-Last Companies, *Business and Society Review*, 105, No. 4, pp. 393-418.
26. Griffin, J.J. (2000). Corporate Social Performance: Research Direction for 21st Century, *Business & Society*, 39, No. 4, pp. 479-491.
27. Griffin, J.J. and J.F. Mahon (1997). The Corporate Social Performance and Corporate Financial Performance Debate; Twenty Five Years of Incomparable Research, *Business and Society*, March (36), pp. 5-31.
28. Hair, J.F., R.E. Anderson, R.L. Tatham and W.C. Black (1998). *Multivariate Data Analysis; 5th international edition*. Prentice Hall International.
29. Hunt, S.D. (1999). The Strategic Imperative and Sustainable Competitive Advantage: Public Policy Implications of Resource-Advantage Theory, *Academy of Marketing Science Journal*, No. 27, pp. 144-159.
30. Hunt, D.S. and R.M. Morgan (1995). The Comparative Advantage Theory of Competition, *Journal of Marketing* 59, No. 2, pp. 1-15.
31. Hunt, D.S. and R.M. Morgan (1997a). Resource Advantage Theory: A Snake Swallowing Its Tail or a General Theory of Competition? *Journal of Marketing*, 61, pp. 74-82.
32. Hunt, D.S. and Morgan R.M. (1997b). Resource Advantage Theory: An Evaluating Theory of Competitive Firm Behavior. *Journal of Economic Issues*, Vol. XXXI, No. 1.
33. Husted, B.W. (2000). A Contingency Theory of Corporate Social Performance, *Business & Society*, 39, No. 1, pp. 24-48.
34. Jawahar, L.M. and G. McLoughlin, (2001). Toward A Descriptive Stakeholder Theory: An Organizational Life Cycle Approach, *Academy of Management Review*, 26, No. 3, pp. 397-414.
35. Joreskog, K.G. (2000). *Latent Variable Scores and Their Uses*. Chicago: Scientific Software International.
36. Kemp, M. (2001). *Corporate Social Responsibility in Indonesia: Quixotic dream or Confident Expectation?* United Nations Research Institute for Social Development; Technology, Business and Society Programme, Paper Number 6.
37. Kumar, K., R. Subramanian and K. Strandholm (2000). Market Orientation and Performance: Does Organizational Matter? *Journal of Applied Business Research*, 18, No. 1, pp. 37-50.
38. Lynch, D.F., S.B. Keller and J. Ozment (2000). The Effect of Logistics Capabilities and Strategy on Firm Performance, *Journal of Business Logistics*, 21, No. 2, pp. 47-67.
39. Mitchell, R.K., B.R. Agle and D.J. Wood (1997). Towards a Theory of Stakeholder Identification and Salience: Defining the Principle of Who and What Really Counts, *Academy of Management Review*, 22, No. 4, pp. 853-886.
40. Moore, G. (2001). Corporate Social and Financial Performance: An Investigation in the U.K. Supermarket Industry. *Journal of Business Ethics*, 34, pp. 299-315.
41. Orlitzky, M. (2000). *Corporate Social Performance: Developing Effective Strategies*. Centre for Corporate Change, Australian Graduate School of Management.

42. Pierick, E.T., T. Beekman, C.N. Van Der Week, M.J.G. Meeusen and R.P.M. De Graaff (2004). *A Framework for Analyzing Corporate Social Performance, Beyond the Wood Model*. Agricultural Economic Research Institute (LEI): The Hague.
43. Porter, M.E. (1980). *Competitive Strategy: Techniques for Analyzing Industries and Competitors*. The Free Press: New York.
44. Porter, M.E. (1996). What is Strategy? *Harvard Business Review*, November-December, pp. 61-78.
45. Porter, M.E. and M.R. Kramer (2003). The Competitive Advantage of Corporate Philanthropy, *Harvard Business Review on Corporate Responsibility*, pp. 27-64.
46. Polonsky, M.J. (1995). A Stakeholder Theory Approach to Designing Environmental Marketing Strategy, *Journal of Business & Industry Marketing*, 10, No. 3, pp. 29-46.
47. Post, J.E., E. Lee Preston and S. Sachs (2002). *Redefining the Corporation, Stakeholder Management and Organizational Wealth*. California, US: Stanford University Press.
48. Preston, L.E., and D.P. O'Bannon (1997). The Corporate Social-Financial Performance Relationship: A typology of Analysis (A Research Note). *Business & Society*, 36, No. 4, pp. 419-429.
49. Primozić K., E. Primozić and J. Leben (1991). *Strategic Choices; Supremacy, Survival, or Sayonara*. New York: McGraw-Hill.
50. Rais, S. and Goedegebuure R.V. (2008). *Stakeholder Orientation and Financial Performance: Evidence from Indonesia*. Maastricht, Netherlands: Maastricht School of Management, Netherlands.
51. Reed, D., (2002). Employing Normative Stakeholder Theory in Developing Countries: A Critical Theory Perspective, *Business and Society*, 41, No. 2, pp. 166-207.
52. Riordan, C.M., R.D. Gatewood J.B. Bill (1997). Corporate Image: Employee Reactions and Implications for Managing Corporate Social Performance, *Journal of Business Ethics*, 16, pp. 401-412.
53. Roman, R.M., S. Hayibor and B.R. Agle (1999). The Relationship between Social and Financial Performance: Repainting a Portrait, *Business & Society*, 38, No.1, pp. 109-125.
54. Ruf, B.M., K. Muralidhar, R.M. Brown, J.J. Janney and K. Paul (2001). An Empirical Investigation of the Relationship between Change in Corporate Social Performance and Financial Performance: A Stakeholder Theory Perspective, *Journal of Business Ethics*, 32, pp. 143-156.
55. Sekaran, U. (1984), *Research Methods for Business: A Skill-Building Approach*, 2nd ed. John Wiley & Sons.
56. Soehadi, A.W. (2003). The Relationships between Supplier Partnership, Environmental Variables and Firm Performance in Retail Industry, *International Journal of Business*, University of Gajah Mada, Yogyakarta, Indonesia 5, No. 2, pp. 167-188.
57. Srivastava, R.A. (2001). *The resource-based view and marketing: The role of market-based assets in gaining competitive advantage*, *Journal of Management*, Vol. 27, No. 6, 777-802.
58. Turban, D.B., and D.W. Greening (1996). Corporate Social Performance and Organizational Attractiveness to Prospective Employees, *Academy of Management Journal*, 40, pp. 658-672.
59. Venkatraman, N. and J.C. Camillius (1984). Exploring the Concept of "Fit" in Strategic Management, *The Academy of Management Review*, 9, No. 3, July, 513.
60. Waddock, S.A., and S.B. Grave (1997). The Corporate Social Performance-Financial Performance Link, *Strategic Management Journal*, 18, No. 4, pp. 303- 319.
61. Wartick, S.L. and P.L. Cochran (1985). The Evolution of the Corporate Social Performance Model. *Academy of Management Review*, 10, no.4, 758-769.
62. Wheelen, T.H. and J.D. Hunger (2004). *Strategic Management and Business Policy*, 9th ed. Upper saddle River, N.J.: Pearson, Prentice Hall, Int. Editions.
63. Wijanto, S.H. (2005). *Structural Equation Modeling (SEM) with LISREL 8.7*. University of Indonesia. Pasca Sarjana Fakultas Ekonomi, Program Studi Ilmu Manajemen.
64. Wood, D.J., (1991a). Corporate Social Performance Revisited, *Academy of Management Review*, 16, No. 4, pp. 691-718.
65. Wood, D.J., (1991b). Social Issue Management: Theory and Research in Corporate Social Performance. *Journal of Management*, 17, no.2, 283-406.
66. Wood, D.J. (1991c). Toward improving corporate social performance, *Business Horizons*, No. July-August, pp. 66-73.
67. Wood, D.J. (1994). Essay: Reflections on Stakeholder Theory. *Toronto Conference, Business and Society*, 33, No. 1, pp. 101-105.
68. Wood, D.J. and R.E. Jones (1995). Stakeholder Mismatching: A Theoretical Problem in Empirical Research on Corporate Social Performance. *The International Journal of Organizational Analysis*, 3, pp. 229-267.

Appendix A. Items and constructs used in the research survey

SHR – Shareholder relation	
SHR1	Increase shareholder value (economic return)
SHR2	Communication with Board of Directors
SHR3	Corporate response on environmental issues
SHR4	Relationship with local authorities and regulator
SHR5	Good governance practices
CSR – customer/consumer relation	
CSR1	Overall customer satisfaction

CSR2	Showing response to customer complaints
CSR3	Provide product information & safety
CSR4	Customer commitment & protection
CSR5	Provide follow-up service
SPR – supplier relation	
SPR1	Overall supplier satisfaction
SPR2	Provide clear product specification
SPR3	Supplier protection over claims of 3rd parties
SPR4	Provide solution on related supplier issues
SPR5	Fulfill supplier rights
EMR – employee relation	
EMR1	Provide equal opportunity
EMR2	Provide work insurance
EMR3	Provide job evaluation
EMR4	Provide career plan system
EMR5	Provide training and development
EMR6	Provide fair remuneration system
EMR7	Provide termination system & retirement plan
EMR8	Relationship with union
EMR9	Provide communication with employees
EMR10	Provide compensation and reward system
CMR – community relation	
CMR1	Provide support for social life of local community
CMR2	Involve in improving environmental condition
CMR3	Efforts against environmental damage
CMR4	Provide job opportunity for community
CMR5	Philanthropic activities
Strategy	
Low-cost strategy – CL	
CL1	Emphasize efficiency
CL2	Provide low production cost
CL3	Provide lower price of product and/or service than competitors
CL4	Invest in cost saving technology
Differentiation strategy – DF	
DF1	Provide new service and/or product development
DF2	Offer product and/or service for special need
DF3	Offer more quality product and/or service than competitors
DF4	Offer highly differentiated product and/or service
VG – value gain performance	
VG1	Productivity increase
VG2	Market share growth
VG3	Sale volume increase
VG4	Overall performance (non-financial)
MG – monetary gain performance	
MG1	Profit margin growth
MG2	Return on equity (ROE) growth
MG3	Revenue growth
MG4	Return on asset (ROA) growth

Notes: Operationalization of the above CSP constructs embraces principles of corporate social responsibility (CSR1) and social responsiveness (CSR2) as stipulated by Wood (1991). Components of CSR1 include principles of legitimacy (Pierick et al., 2004, p. 34), divided into four categories: a) economic responsibility: financial – economic rationale, b) legal responsibility – a set of rules; c) ethical responsibility – respect to others; d) discretionary responsibility – free choice by managers to act (morality aspect). CSR2 is defined as capacity of the firm to respond its environment such as the way firm approaches its environment and firm attitude towards its environment.