

David Hua (USA), Heng-Chih Chou (Taiwan), David Wang (Taiwan)

A defaultable callable bond pricing model

Abstract

This paper presents a 3D model for pricing defaultable bonds with embedded call options. The pricing model incorporates three essential ingredients in the pricing of defaultable bonds: stochastic interest rate, stochastic default risk, and call provision. Both the stochastic interest rate and the stochastic default risk are modeled as a square-root diffusion process. The default risk process is allowed to be correlated with the default-free term structure. The call provision is modeled as a constraint on the value of the bond in the finite difference scheme. The numerical example shows that the 3D model is capable of pricing defaultable bonds with embedded call options adequately. This paper can provide new insight for future research on defaultable bond pricing models.

Keywords: defaultable bond, embedded option, square-root diffusion process, partial differential equation, finite difference method.

JEL Classification: C00, G13.

Introduction

The pricing of defaultable securities has occupied a central place in the academic and practitioner literature. The standard theoretical paradigm for pricing defaultable securities is the contingent claims approach pioneered by Black and Scholes (1973) [1]. Much of the literature follows Merton (1974) [2] by explicitly linking the risk of a firm's default to the variability in the firm's asset value. Although this line of research has proven very useful in addressing the qualitatively important aspects of pricing defaultable securities, it has been less successful in practical applications. The lack of success owes to the fact that firms' capital structures are typically quite complex and priority rules are often violated. In response to these difficulties, an alternative modeling approach has been pursued in a number of papers, including Madan and Unal (1994) [3], Jarrow and Turnbull (1995) [4], Duffie and Singleton (1999) [5]. At each instant, there is some probability that a firm defaults on its obligation. This is called the instantaneous probability of default. The processes of both this probability and the recovery rate determine the value of default risk. Although these processes are not formally linked to the firm's asset value, there is presumably some underlying relation, thus Duffie and Singleton describe this alternative approach as a reduced-form model (Duffie, 1999) [6].

This paper is an effort to develop one such model in a 3D setting for pricing defaultable bonds with embedded call options. The remainder of this paper is organized as follows. Section 1 presents the model. Section 2 describes the methodology. Section 3 provides a numerical example. The last section concludes this paper.

1. Model

We derive the pricing model for defaultable bonds with embedded call options by adopting Duffie and Singleton (1999) [5]'s reduced-form approach and Hull (2000) [7]'s replicating-portfolio approach.

According to Duffie and Singleton, defaultable bonds can be valued by discounting at a default-adjusted interest rate, R :

$$R = r + hL, \quad (1)$$

where r is the risk-free interest rate, h is the hazard rate for default (i.e., the instantaneous probability of default) at time t , and L is the loss rate (i.e., the expected fractional loss in the market value) if default was to occur at time t , conditional on the information available up to time t . That is, the price at time 0 of a defaultable discount bond, f , is:

$$f = E[\exp(-\int_0^T R dt) X], \quad (2)$$

where X is the face value, T is the maturity time, and E is the risk-neutral, conditional expectation at date 0. This is natural, in that hL is the risk neutral mean-loss rate of the defaultable discount bond due to default. Discounting at the default-adjusted short-term interest rate R therefore accounts for both the probability and timing of default, as well as for the effect of losses on default. A key feature of Equation (2) is that, assuming the risk neutral mean-loss rate process hL being given exogenously, standard term-structure models for default-free debt are directly applicable to defaultable debt by parameterizing R instead of r (Duffie and Singleton, 1999) [5].

We assume that both the default-adjusted interest rate R and the hazard rate h fit a Cox, Ingersoll, and Ross (CIR)-style model (1985) [8], a square-root diffusion model:

$$dR = a_R (b_R - R)dt + \sigma_R \sqrt{R} dz_R, \quad (3)$$

$$dh = a_h(b_h - h)dt + \sigma_h \sqrt{h} dz_h, \quad (4)$$

where dz_R and dz_h are Wiener processes, and the drift and the diffusion parameters are constants and are assumed to be known. The CIR-style model incorporates mean reversion and ensures that the default-adjusted interest rates and the hazard rates are always non-negative. As for the loss rate L , it is assumed to be a constant.

We make the assumption that there are a total of three defaultable bonds whose prices depend on the default-adjusted interest rate R and the hazard rate h . Because the three defaultable bonds are all dependent on the default-adjusted interest rate R and the hazard rate h , it follows from Ito's lemma that the price of the j th defaultable bond, f_j , follows a diffusion process:

$$df_j = \mu_j f_j dt + \sigma_{Rj} f_j dz_R + \sigma_{hj} f_j dz_h, \quad (5)$$

where

$$\begin{aligned} \mu_j f_j &= \frac{\partial f_j}{\partial t} + \frac{\partial f_j}{\partial R} a_R(b_R - R) + \frac{\partial f_j}{\partial h} a_h(b_h - h) + \\ &+ \frac{1}{2} (\sigma_R \sqrt{R})^2 \frac{\partial^2 f_j}{\partial R^2} + \rho_{Rh} \sigma_R \sqrt{R} \sigma_h \sqrt{h} \frac{\partial^2 f_j}{\partial R \partial h} + \\ &+ \frac{1}{2} (\sigma_h \sqrt{h})^2 \frac{\partial^2 f_j}{\partial h^2}, \end{aligned} \quad (6)$$

$$\sigma_{Rj} f_j = \frac{\partial f_j}{\partial R} \sigma_R \sqrt{R}, \quad (7)$$

$$\sigma_{hj} f_j = \frac{\partial f_j}{\partial h} \sigma_h \sqrt{h}. \quad (8)$$

In these equations, μ_j is the instantaneous mean rate of return provided by f_j , σ_{Rj} and σ_{hj} are the components of the instantaneous standard deviation of the rate of return provided by f_j that may be attributed to R and h , and ρ_{Rh} is the correlation between dz_R and dz_h .

Because there are three defaultable bonds and two Wiener processes in equation (5), it is possible to form an instantaneously riskless portfolio, Π , using the defaultable bonds. Define k_j as the amount of the j th defaultable bond in the portfolio, so that

$$\Pi = \sum_j k_j f_j. \quad (9)$$

The k_j must be chosen so that the stochastic components of the returns from the defaultable bonds are eliminated. From equation (5) this means that

$$\sum_j k_j \sigma_{Rj} f_j = 0, \quad (10)$$

$$\sum_j k_j \sigma_{hj} f_j = 0. \quad (11)$$

The return from the portfolio is then given by

$$d\Pi = \sum_j k_j \mu_j f_j dt. \quad (12)$$

The cost of setting up the portfolio is $\sum_j k_j f_j$. If

there are no arbitrage opportunities, the portfolio must earn the default-adjusted interest rate, so that

$$\sum_j k_j \mu_j f_j = R \sum_j k_j f_j \quad (13)$$

or

$$\sum_j k_j f_j (\mu_j - R) = 0. \quad (14)$$

Equations (10), (11) and (14) can be regarded as three homogeneous linear equations in the k_j 's. The k_j 's are not all zero. From a well-known theorem in linear algebra, equations (10), (11) and (14) can be consistent only if

$$f_j (\mu_j - R) = \lambda_R \sigma_{Rj} f_j + \lambda_h \sigma_{hj} f_j \quad (15)$$

or

$$\mu_j - R = \lambda_R \sigma_{Rj} + \lambda_h \sigma_{hj} \quad (16)$$

for λ_R and λ_h that are dependent only on the default-adjusted interest rate R , the hazard rate h and time t .

Substituting from equations (6), (7) and (8) into equation (15), we obtain

$$\begin{aligned} \frac{\partial f_j}{\partial t} + \frac{\partial f_j}{\partial R} a_R(b_R - R) + \frac{\partial f_j}{\partial h} a_h(b_h - h) + \\ + \frac{1}{2} (\sigma_R \sqrt{R})^2 \frac{\partial^2 f_j}{\partial R^2} + \rho_{Rh} \sigma_R \sqrt{R} \sigma_h \sqrt{h} \frac{\partial^2 f_j}{\partial R \partial h} + \\ + \frac{1}{2} (\sigma_h \sqrt{h})^2 \frac{\partial^2 f_j}{\partial h^2} - R f_j = \lambda_R \frac{\partial f_j}{\partial R} \sigma_R \sqrt{R} + \lambda_h \frac{\partial f_j}{\partial h} \sigma_h \sqrt{h} \end{aligned} \quad (17)$$

that reduces to

$$\begin{aligned} \frac{\partial f_j}{\partial t} + \frac{\partial f_j}{\partial R} [a_R(b_R - R) - \lambda_R \sigma_R \sqrt{R}] + \\ + \frac{\partial f_j}{\partial h} [a_h(b_h - h) - \lambda_h \sigma_h \sqrt{h}] + \frac{1}{2} (\sigma_R \sqrt{R})^2 \frac{\partial^2 f_j}{\partial R^2} + \\ + \rho_{Rh} \sigma_R \sqrt{R} \sigma_h \sqrt{h} \frac{\partial^2 f_j}{\partial R \partial h} + \frac{1}{2} (\sigma_h \sqrt{h})^2 \frac{\partial^2 f_j}{\partial h^2} - R f_j = 0. \end{aligned} \quad (18)$$

Dropping the subscripts to f , we deduce that any defaultable bond whose price, f , is contingent on the default-adjusted interest rate, R , the hazard rate, h , and time, t , satisfies the second-order differential equation

$$\begin{aligned} & \frac{\partial f}{\partial t} + \frac{\partial f}{\partial R} [a_R(b_R - R) - \lambda_R \sigma_R \sqrt{R}] + \\ & + \frac{\partial f}{\partial h} [a_h(b_h - h) - \lambda_h \sigma_h \sqrt{h}] + \frac{1}{2} (\sigma_R \sqrt{R})^2 \frac{\partial^2 f}{\partial R^2} + \\ & + \rho_{Rh} \sigma_R \sqrt{R} \sigma_h \sqrt{h} \frac{\partial^2 f}{\partial R \partial h} + \\ & + \frac{1}{2} (\sigma_h \sqrt{h})^2 \frac{\partial^2 f}{\partial h^2} - Rf = 0. \text{ Q.E.D.} \end{aligned} \quad (19)$$

On a coupon date, the bond value must jump by the amount of the coupon payment. Hence, to incorporate coupon payments into the model, we impose a jump condition:

$$f(R, h, t_C^-) = f(R, h, t_C^+) + K_C, \quad (20)$$

where a coupon of K_C is received at time t_C .

Bonds often have a call feature which gives the issuing company the right to purchase back the bond at any time during specified periods for a specified amount. According to the no-arbitrage argument, to incorporate a call feature into the model, we must impose a constraint on the bond's value:

$$f(R, h, t_D) \leq X_D, \quad (21)$$

where X_D is the call price and t_D is the call date.

To find a unique solution of equation (19), we must impose one final condition and four boundary conditions.

The final condition corresponds to the payoff at maturity and so for a coupon-paying bond:

$$f(R, h, T) = P_T + K_T, \quad (22)$$

where a principal amount of P_T and a coupon payment of K_T are received at maturity.

The first boundary condition, when the default-adjusted interest rate, R , approaches zero percent, can be stated as:

$$f(R, h, t) = f(R, h, T) e^{-R(T-t)} = f(R, h, T). \quad (23)$$

The second boundary condition, when the default-adjusted interest rate, R , approaches infinity, can be stated as:

$$f(R, h, t) = f(R, h, T) e^{-R(T-t)} = 0. \quad (24)$$

The third boundary condition, when the hazard rate, h , approaches zero percent, can be stated as:

$$\begin{aligned} f(R, h, t) &= f(R, h, T) e^{-R(T-t)} = \\ &= f(R, h, T) e^{-(r+hL)(T-t)} = \\ &= f(R, h, T) e^{-r(T-t)}. \end{aligned} \quad (25)$$

The fourth boundary condition, when the hazard rate, h , approaches infinity, can be stated as:

$$\begin{aligned} f(R, h, t) &= f(R, h, T) e^{-R(T-t)} = \\ &= f(R, h, T) e^{-(r+hL)(T-t)} = 0. \end{aligned} \quad (26)$$

2. Methodology

We solve the pricing model for defaultable bonds with embedded call options by a 3D explicit finite difference method (Hull, 2003 [9]; Wilmott, 2000 [10]).

Suppose that the number of months to maturity is T . We divide this into L equally spaced intervals of length $\Delta t = T/L$. Δt is fixed at one month. A total of $L+1$ times are, therefore, considered:

$$0, \Delta t, 2 \Delta t, \dots, T.$$

Suppose that h_{max} is a hazard rate sufficiently high that, when it is reached, the bond has virtually no value. We define $\Delta h = h_{max}/M$ and consider a total of $M+1$ equally spaced hazard rates:

$$0, \Delta h, 2 \Delta h, \dots, h_{max}.$$

Δh is set to be one percent.

Suppose that R_{max} is a default-adjusted interest rate sufficiently high that, when it is reached, the bond has virtually no value. We define $\Delta R = R_{max}/N$ and consider a total of $N+1$ equally spaced default-adjusted interest rates:

$$0, \Delta R, 2 \Delta R, \dots, R_{max}.$$

ΔR is set to be one percent.

The time points, hazard rate points and default-adjusted interest rate points define a 3D grid consisting of a total of $(L+1)(M+1)(N+1)$ points as shown in Figure 1. The (i, j, k) point on the 3D grid is the point that corresponds to default-adjusted interest rate $i \Delta R$, hazard rate $j \Delta h$ and time $k \Delta t$. We use the variable $f_{i,j}^k$ to denote the value of the bond at the (i, j, k) point.

Recall that the differential equation for the price of a defaultable bond, $f(R, h, t)$, is given as:

$$\begin{aligned}
 & \frac{\partial f}{\partial t} + \frac{\partial f}{\partial R} [a_R(b_R - R) - \lambda_R \sigma_R \sqrt{R}] + \\
 & + \frac{\partial f}{\partial h} [a_h(b_h - h) - \lambda_h \sigma_h \sqrt{h}] + \\
 & + \frac{1}{2} (\sigma_R \sqrt{R})^2 \frac{\partial^2 f}{\partial R^2} + \rho_{Rh} \sigma_R \sqrt{R} \sigma_h \sqrt{h} \frac{\partial^2 f}{\partial R \partial h} + \\
 & + \frac{1}{2} (\sigma_h \sqrt{h})^2 \frac{\partial^2 f}{\partial h^2} - Rf = 0. \quad (27)
 \end{aligned}$$

For an interior point (i, j, k) in the 3D grid, $\frac{\partial f}{\partial t}$ can be approximated by using a symmetric central difference:

$$\frac{\partial f}{\partial t} = \frac{f_{i,j}^k - f_{i,j}^{k+1}}{\Delta t}, \quad (28)$$

$\frac{\partial f}{\partial R}$ can be approximated by using a symmetric central difference:

$$\frac{\partial f}{\partial R} = \frac{f_{i+1,j}^k - f_{i-1,j}^k}{2\Delta R}, \quad (29)$$

$\frac{\partial f}{\partial h}$ can be approximated by using a symmetric central difference:

$$\frac{\partial f}{\partial h} = \frac{f_{i,j+1}^k - f_{i,j-1}^k}{2\Delta h}, \quad (30)$$

$\frac{\partial^2 f}{\partial R^2}$ can be approximated by using a symmetric central difference:

$$\frac{\partial^2 f}{\partial R^2} = \frac{f_{i+1,j}^k - 2f_{i,j}^k + f_{i-1,j}^k}{\Delta R^2}, \quad (31)$$

$\frac{\partial^2 f}{\partial R \partial h}$ can be approximated by using a symmetric central difference:

$$\frac{\partial^2 f}{\partial R \partial h} = \frac{f_{i+1,j+1}^k - f_{i+1,j-1}^k - f_{i-1,j+1}^k + f_{i-1,j-1}^k}{4\Delta R \Delta h}, \quad (32)$$

and $\frac{\partial^2 f}{\partial h^2}$ can be approximated by using a symmetric central difference:

$$\frac{\partial^2 f}{\partial h^2} = \frac{f_{i,j+1}^k - 2f_{i,j}^k + f_{i,j-1}^k}{\Delta h^2}. \quad (33)$$

Substituting equations (28), (29), (30), (31), (32) and (33) into the differential equation (27) and not-

ing that $R = i \Delta R$, $h = j \Delta h$ and $f = f_{i,j}^k$, the corresponding difference equation can be shown as:

$$\begin{aligned}
 & \frac{f_{i,j}^k - f_{i,j}^{k+1}}{\Delta t} + \frac{f_{i+1,j}^k - f_{i-1,j}^k}{2\Delta R} [a_R(b_R - i\Delta R) - \lambda_R \sigma_R \sqrt{i\Delta R}] + \\
 & + \frac{f_{i,j+1}^k - f_{i,j-1}^k}{2\Delta h} [a_h(b_h - j\Delta h) - \lambda_h \sigma_h \sqrt{j\Delta h}] + \\
 & + \frac{1}{2} (\sigma_R \sqrt{i\Delta R})^2 \frac{f_{i+1,j}^k - 2f_{i,j}^k + f_{i-1,j}^k}{\Delta R^2} + \\
 & + \rho_{Rh} \sigma_R \sqrt{i\Delta R} \sigma_h \sqrt{j\Delta h} \frac{f_{i+1,j+1}^k - f_{i+1,j-1}^k - f_{i-1,j+1}^k + f_{i-1,j-1}^k}{4\Delta R \Delta h} + \\
 & + \frac{1}{2} (\sigma_h \sqrt{j\Delta h})^2 \frac{f_{i,j+1}^k - 2f_{i,j}^k + f_{i,j-1}^k}{\Delta h^2} - (i\Delta R) f_{i,j}^k = 0, \quad (34)
 \end{aligned}$$

where $i = 0, 1, \dots, N$, $j = 0, 1, \dots, M$ and $k = 0, 1, \dots, L$. Rearranging terms, this equation becomes:

$$\begin{aligned}
 & A_{i,j} f_{i,j}^k + B_i (f_{i+1,j}^k + f_{i-1,j}^k) + C_j (f_{i,j+1}^k + f_{i,j-1}^k) + \\
 & + D_{i,j} (f_{i+1,j+1}^k + f_{i+1,j-1}^k + f_{i-1,j+1}^k + f_{i-1,j-1}^k) = f_{i,j}^{k+1}, \quad (35)
 \end{aligned}$$

where

$$\begin{aligned}
 A_{i,j} &= 1 - \frac{1}{\Delta R^2} (\sigma_R \sqrt{i\Delta R})^2 \Delta t - \\
 & - \frac{1}{\Delta h^2} (\sigma_h \sqrt{j\Delta h})^2 \Delta t - (i\Delta R) \Delta t, \\
 B_i &= \frac{1}{2\Delta R} [a_R(b_R - i\Delta R) - \lambda_R \sigma_R \sqrt{i\Delta R}] \Delta t + \\
 & + \frac{1}{2\Delta R^2} (\sigma_R \sqrt{i\Delta R})^2 \Delta t, \\
 C_j &= \frac{1}{2\Delta h} [a_h(b_h - j\Delta h) - \lambda_h \sigma_h \sqrt{j\Delta h}] \Delta t + \\
 & + \frac{1}{2\Delta h^2} (\sigma_h \sqrt{j\Delta h})^2 \Delta t, \\
 D_{i,j} &= \frac{1}{4\Delta R \Delta h} \rho_{Rh} \sigma_R \sqrt{i\Delta R} \sigma_h \sqrt{j\Delta h} \Delta t,
 \end{aligned}$$

$i = 0, 1, \dots, N$, $j = 0, 1, \dots, M$ and $k = 0, 1, \dots, L$.

The value of the bond at time T is $P_T + K_T$, where P_T is the principal amount and K_T is the coupon payment. Hence,

$$f_{i,j}^k = P_T + K_T \quad (36)$$

for $i = 0, 1, \dots, N$, $j = 0, 1, \dots, M-1$ and $k = 0$.

The value of the bond when the default-adjusted interest rate is zero percent is $f(R, h, T)$. Hence,

$$f_{i,j}^{k+1} = f_{i,j}^k \quad (37)$$

for $i = 0, j = 0, 1, \dots, M-1$ and $k = 0, 1, \dots, L-1$.

We assume that the bond is worth zero when the default-adjusted interest rate is one hundred percent, so that

$$f_{i,j}^{k+1} = 0 \quad (38)$$

for $i = N, j = 0, 1, \dots, M-1$ and $k = 0, 1, \dots, L-1$.

The value of the bond when the hazard rate is zero percent is $f(R, h, T)e^{-r(T-t)}$. Hence,

$$f_{i,j}^{k+1} = f_{i,j}^k e^{-r(T-t)} \quad (39)$$

for $i = 1, 2, \dots, N-1, j = 0$ and $k = 0, 1, \dots, L-1$.

We assume that the bond is worth zero when the hazard rate is one hundred percent, so that

$$f_{i,j}^{k+1} = 0 \quad (40)$$

for $i = 0, 1, \dots, N, j = M$ and $k = -1, 0, \dots, L-1$.

To incorporate coupon payments into the model, we impose a jump condition. Hence,

$$f_{i,j}^k = f_{i,j}^k + K_C \quad (41)$$

for $i = 0, 1, \dots, N-1, j = 0, 1, \dots, M-1, k = t_C$ or the coupon date and K_C is the coupon payment.

To incorporate call features into the model, we impose a constraint on the bond's value. Hence,

$$f_{i,j}^k \leq X_D \quad (42)$$

for $i = 0, 1, \dots, N-1, j = 0, 1, \dots, M-1, k = t_D$ or the call date and X_D is the call price.

Equations (36), (37), (38), (39) and (40) define the value of the bond along the five planes of the 3D grid in Figure 1, where $t = T, R = 0\%, R = 100\%, h = 0\%$ and $h = 100\%$. Equation (35) defines the value of the bond at all other points.

Equation (35) shows that there are nine known bond values linked to one unknown bond value. See Figure 2. Hence, for each time layer there are $(N-1)(M-1)$ equations in $(N-1)(M-1)$ unknowns; the boundary conditions yield the values at the four boundaries for each time layer and the final condition gives the values in the last time layer.

To find the bond value of interest, go backwards in time, solving for a sequence of linear equations. Eventually, $f_{1,1}^L, f_{1,2}^L, f_{1,3}^L, \dots, f_{N-1,M-1}^L$ are obtained. One of these is the bond price of interest. If the initial default-adjusted interest rate or the initial hazard rate does not lie on the grid point, we use a linear interpolation between the two bond prices on the neighboring grid points to find the bond price of interest.

3. Numerical example

We validate the pricing model for defaultable bonds with embedded call options by a numerical example.

The input data used for the model are summarized in Table 1. For the default-adjusted interest rate model, $a_R = 0.35, b_R = 0.20, \sigma_R = 0.15$ and $\lambda_R = -0.50$. For the hazard rate model, $a_h = 0.30, b_h = 0.15, \sigma_h = 0.10$ and $\lambda_h = -0.50$. The loss rate L is set to be 0.50. The correlation ρ_{Rh} is set to be 0.20. The bond to be priced is assumed to have a maturity T of ten years. The coupon payment K is set to be \$10.00. Both the principal amount P and the call price X are set to be \$100.00. We assume that the coupon is paid semiannually in the 6th month and the 12th month each year, and that the bond is callable in the 3rd month and the 9th month of the 4th year, the 5th year, the 6th year and the 7th year.

We first compute the value of both the straight bond and the callable bond using different values of the risk-free interest rate r . Intuitively, we expect that as the value of r increases, the value of both the straight bond and the callable bond will decrease, and that the value of the straight bond will be greater than the value of the callable bond. The results are reported in Table 2 and depicted in Figure 3. As expected, the results show that as the value of r increases, the value of both the straight bond and the callable bond decreases, and that, for r less than or equal to twenty-five percent, the value of the straight bond is greater than the value of the callable bond.

We also compute the value of the callable bond with various numbers of call dates using different values of r . With one call date, the bond is callable in the 3rd month of the 4th year; with two call dates, the bond is callable in the 3rd month and the 9th month of the 4th year; with three call dates, the bond is callable in the 3rd month and the 9th month of the 4th year and the 3rd month of the 5th year; with four call dates, the bond is callable in the 3rd month and the 9th month of the 4th year and the 5th year; with five call dates, the bond is callable in the 3rd month and the 9th month of the 4th year and the 5th year and the 3rd month of the 6th year. Intuitively, we expect that as the number of call dates increases, the value of the callable bond will decrease. The results are reported in Table 3 and depicted in Figure 4. As expected, the results show that, for r less than or equal to five percent, as the number of call dates increases, the value of the callable bond decreases.

Conclusion

This paper presents a 3D model for pricing defaultable bonds with embedded call options. The

pricing model incorporates three essential ingredients in the pricing of defaultable bonds: stochastic interest rate, stochastic default risk, and call provision. Both the stochastic interest rate and the stochastic default risk are modeled as a square-root diffusion process. The default risk process is allowed to be correlated with the default-free term structure. The call provision is modeled as a constraint on the value of the bond

in the finite difference scheme. The numerical example shows that the 3D model is capable of pricing defaultable bonds with embedded call options adequately. The model is by no means a complete success. To improve the model, one can assume that the recovery rate in the event of default varies stochastically through time. In summary, this paper can provide new insight for future research on defaultable bond pricing models.

References

1. F. Black and M. Scholes (1973), The pricing of options and corporate liabilities. *Journal of Political Economy*. 81: 637-654.
2. R.C. Merton (1974), On the pricing of corporate debt: The risk structure of interest rates. *Journal of Finance*. 29: 449-470.
3. D.B. Madan and H. Unal (1994), Pricing the Risks of Default. Working Paper, Wharton School, University of Pennsylvania.
4. R.A. Jarrow and S.M. Turnbull (1995), Pricing derivatives on financial securities subject to credit risk. *Journal of Finance*. 50: 53-86.
5. D. Duffie and K.J. Singleton (1999), Modeling the term structure of defaultable bonds. *Review of Financial Studies*. 12: 687-720.
6. G. Duffee (1999), Estimating the price of default risk. *Review of Financial Studies*. 12: 197-226.
7. J. Hull (2000), *Options, Futures, and Other Derivatives*. New Jersey: Prentice Hall.
8. J. Cox, J. Ingersoll and S. Ross (1985), A theory of the term structure of interest rates. *Econometrica*. 53: 385-408.
9. J. Hull (2003), *Options, Futures, and Other Derivatives*. New Jersey: Prentice Hall.
10. P. Wilmott (2000), *Quantitative Finance*. New York: John Wiley & Sons.

Appendix

Table 1. The input data used for the model

Default-adjusted interest rate model:		Hazard rate model:	
Reverting speed a_R	0.35	Reverting speed a_h	0.30
Reverting level b_R	0.20	Reverting level b_h	0.15
Volatility σ_R	0.15	Volatility σ_h	0.10
Market price of risk λ_R	-0.50	Market price of risk λ_h	-0.50
Loss given default:		Correlation between R and h:	
Loss rate L	0.50	Correlation ρ_{Rh}	0.20
Bond characteristics:			
Maturity year T	10.00	Principal amount P	\$100.00
Coupon payment K	\$10.00	Call price X	\$100.00

Table 2. The bond values obtained by the model for the straight bond and the callable bond

Interest rate	Straight bond	Callable bond
0%	\$300.0000	\$160.0000
5%	\$106.2483	\$103.3899
10%	\$100.9673	\$95.8269
15%	\$84.5680	\$86.2457
20%	\$93.3852	\$83.7381
25%	\$83.2655	\$57.5245
30%	\$51.8970	\$77.1003
35%	\$75.4322	\$54.9788

Table 2 (cont.). The bond values obtained by the model for the straight bond and the callable bond

Interest rate	Straight bond	Callable bond
40%	\$108.5197	\$49.4651
45%	\$54.3336	\$58.6361
50%	\$86.9984	\$80.6622
55%	\$51.1595	\$63.3907
60%	\$58.4502	\$53.7722
65%	\$58.1146	\$47.7598
70%	\$47.6593	\$32.0013
75%	\$48.2886	\$52.7612
80%	\$25.1535	\$33.7920
85%	\$36.2448	\$33.6953
90%	\$30.8447	\$38.4609
95%	\$30.8861	\$36.4523
100%	\$0.0000	\$0.0000

Table 3. The bond values obtained by the model for the callable bond with various numbers of call dates

Interest rate	One call date	Two call dates	Three call dates	Four call dates	Five call dates
0%	\$160.0000	\$160.0000	\$160.0000	\$160.0000	\$160.0000
5%	\$137.5249	\$126.6696	\$111.5418	\$121.7842	\$92.7850
10%	\$101.0545	\$122.3038	\$111.7092	\$76.4883	\$113.2784
15%	\$99.6830	\$120.2098	\$105.0775	\$117.3193	\$107.1442
20%	\$108.9300	\$88.3653	\$111.3260	\$78.7300	\$113.3002
25%	\$86.6670	\$78.6220	\$76.4078	\$96.8279	\$82.0580
30%	\$82.9879	\$63.0716	\$83.8521	\$65.2455	\$67.1679
35%	\$91.6000	\$65.1001	\$68.0214	\$81.1618	\$90.7496
40%	\$63.6140	\$60.5333	\$82.7413	\$77.0803	\$61.1198
45%	\$74.7206	\$57.2084	\$77.3416	\$42.5685	\$51.3476
50%	\$67.1843	\$65.1175	\$40.3724	\$46.6710	\$50.5664
55%	\$76.2999	\$45.7887	\$54.8481	\$53.1783	\$45.0959
60%	\$57.7708	\$61.1667	\$56.4496	\$40.5881	\$42.1916
65%	\$47.6409	\$48.7265	\$45.6140	\$48.2443	\$34.1868
70%	\$60.4386	\$32.5112	\$35.0392	\$46.0530	\$53.1147
75%	\$48.8009	\$28.5854	\$28.2614	\$42.3923	\$38.9696
80%	\$29.6277	\$32.3797	\$35.8705	\$29.2817	\$24.8010
85%	\$31.6728	\$46.8083	\$20.0052	\$31.0321	\$28.1002
90%	\$29.1352	\$23.1515	\$23.3416	\$32.7578	\$30.2341
95%	\$27.9046	\$20.8893	\$31.5143	\$28.7969	\$24.8387
100%	\$0.0000	\$0.0000	\$0.0000	\$0.0000	\$0.0000

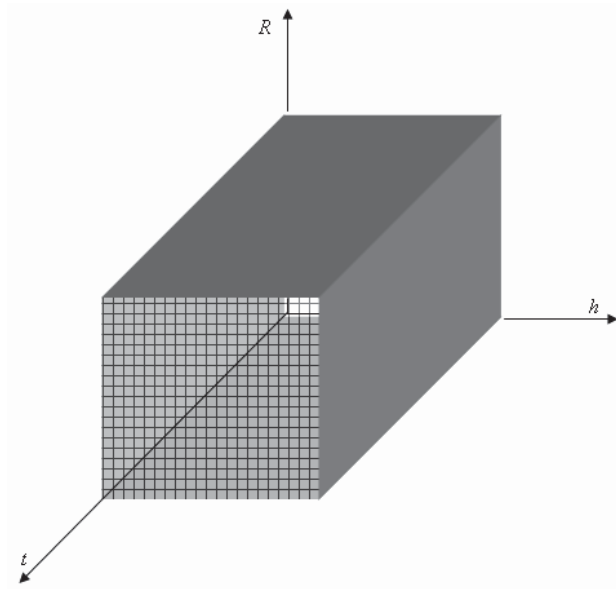

Fig. 1. The 3D finite difference grid



Fig. 2. The relationship between bond values in the 3D explicit finite difference method

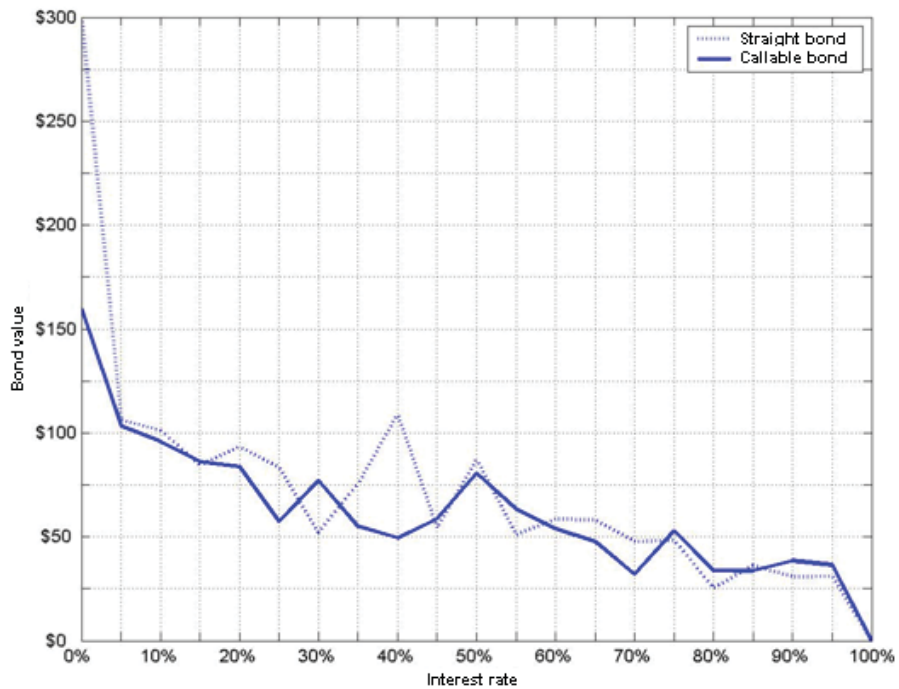

Fig. 3. The bond values obtained by the model for the straight bond and the callable bond

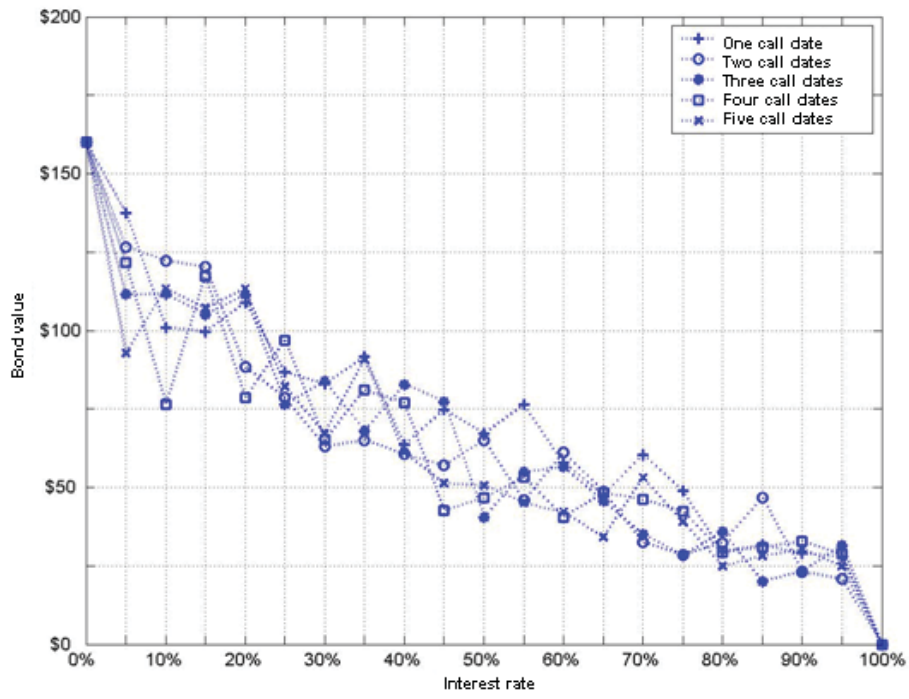

Fig. 4. The bond values obtained by the model for the callable bond with various numbers of call dates